

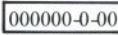



## Notes for using this parts book

1. Pages A~F and Z show all parts for model LT2-832-3.
2. If the symbol  or  is in the "Parts No." column or the "Assembly No." column, please refer to the separate parts list (page 26).
3. The symbol  in the "Parts No." column indicates that the Parts is not available for supply. If, however, there is a number in the "Assembly No." column, the parts can be ordered as an assembly. Please, therefore, order by using the Assembly No.
4. If the \* symbol is found before the Parts No., order this parts together with its paired parts.
5. For page 7 and after, also refer to the separate parts list (classified by specifications) on page 26.
6. This book was prepared based on information available in October, 1979.
7. Parts are subject to changes in design without prior notice.

## Anmerkungen zum Gebrauch dieses Stücklistebuches

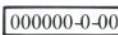
1. Auf den Seiten A—F und Z sind alle Teile des Modells LT2-832-3 abgebildet.
2. Wenn in der Stücknummer oder Gerätesatznummer Spalte das Zeichen  oder  steht, schlagen Sie bitte bei der gesonderte Stückliste (Seite 26) nach.
3. Dieses Zeichen  in der Spalte "Teilnummer" bedeutet, daß dieser Teil nicht lieferbar ist. Wenn jedoch in der Spalte "Gerätesatznummer" eine Nummer steht, kann dieser Teil als ein Geräteteilsatz bestellt werden. Bestellen Sie daher bitte mit dieser Gerätesatznummer.
4. Bei diesem Zeichen \* vor der Teilnummer bestellen Sie bitte diesen Teil paarweise, zusammen mit seinem Gegenstück.
5. Für Seite 7 ff. sehen Sie bitte auch die gesonderte Stückliste (geordnet nach den Spezifikationen) auf Seite 26.
6. Dieses Buch basiert auf den Informationen vom Oktober 1979.
5. Modelländerungen sind vorbehalten.

## CONTENTS

A. Machine Body and Threading .....	1
B. Upper Shaft, Needle Bar and Rocking Mechanism .....	2
C. Presser Foot Mechanism .....	3
D. Feed Mechanism .....	4
E. Lower Shaft, Rotary Hook Mechanism .....	5
F. Lubrication .....	6
G. -400 · -500 Specification.....	7
H. -400 · -500 Specification .....	8
J. -400 · -500 Specification .....	9
K. Thread Wiper, Reverse Switch Mechanism	
-400 · -500 Specification .....	10
L. -400 Specification .....	11
M. Synchronizer Mechanism -400 · -500 Specification .....	12
N. Thread Trimmer and Tension Release Mechanism	
-500 Specification .....	13
Q. Control Box Mechanism -500 Specification.....	14
R. Presser Foot Lifter Cord Mechanism -500 Specification .....	15
S. Control Box Mechanism -400 · -500 Specification .....	16
T. Motor (Part 1) -400 · -500 Specification .....	17
T. Motor (Part 2) -400 · -500 Specification .....	18
Z. Accessories .....	19
Gauge Parts for Standard (-1 · -3 · -5) .....	20
Gauge Parts for Thread Trimmer (-400 · -500) .....	23
GAUGE PARTS LIST .....	24
DIFFERENT PARTS LIST .....	26
INDEX .....	35

# A. Machine Body and Threading

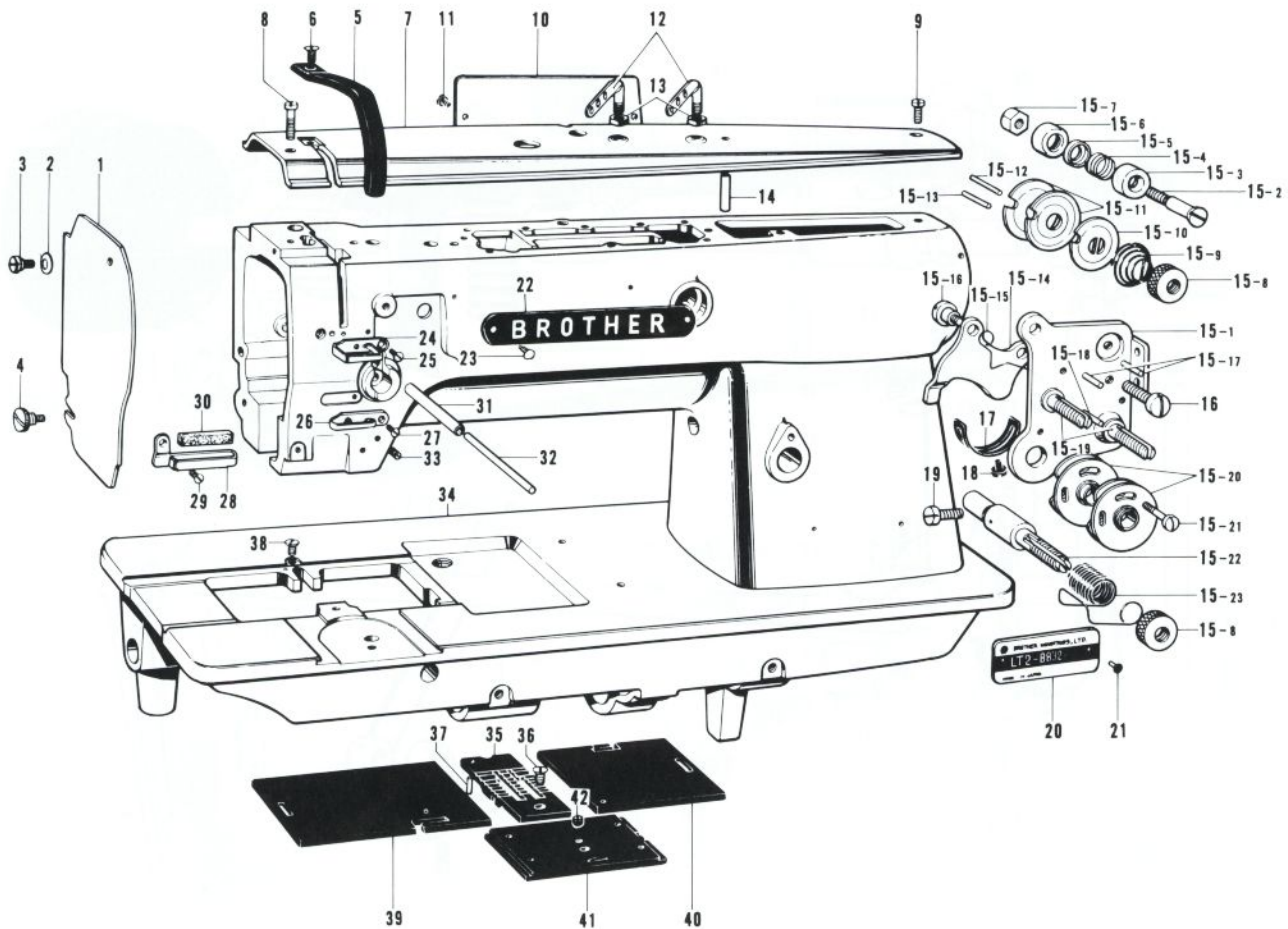

Ref. No.	Name of Parts	Q'ty	Parts No.	Assembly No.	Ref. No.	Name of Parts	Q'ty	Parts No.	Assembly No.
A- 1	Face Plate	1	151101-0-01		A-15-19	Tension Stud	2		A-15 Upper Tension Control Assembly
A- 2	Spring Washer	1	146598-0-01		A-15-20	Spring Guide	2	108254-0-01	
A- 3	Stud Screw	1	153112-0-01		A-15-21	Screw	1	144682-0-01	
A- 4	Screw	1	106120-0-02		A-15-22	Tension Stud	1	144680-0-01	
A- 5	Thread Take-up Cover	1	112561-0-02		A-15-23	Thread Take-up Spring	1	144681-0-01	
A- 6	Screw	1	107231-0-02		A-16	Screw	1	009681-0-14	
A- 7	Arm Top Cover	1	112560-0-01		A-17	Stopper	1	112709-0-01	
A- 8	Screw	1	009681-6-13		A-18	Screw	1	009670-6-12	
A- 9	Screw	1	009681-0-13		A-19	Screw	1	100064-0-02	
A-10	Rear Cover	1	112566-0-01		A-20	Model Plate "BROTHER"	1		
A-11	Screw	2	009670-6-12		A-21	Pin	2		
A-12	Top Cover Thread Guide	2	140527-0-01		A-22	Name Plate	1		
A-13	Nut	2	150553-0-03		A-23	Screw	2		
A-14	Oil Pipe	1	112696-0-00		A-24	Arm Thread Guide Upper	1	108266-0-01	
A-15- 1	Upper Thread Tension Plate	1		A-15 Upper Tension Control Assembly	A-25	Screw	1	108960-0-04	
A-15- 2	Screw	2	144689-0-01		A-26	Arm Thread Guide, Center	1	112658-0-01	
A-15- 3	Thread Guide Cap	2	144685-0-01		A-27	Screw	1	108960-0-04	
A-15- 4	Thread Guide Spring	2	144688-0-01		A-28	Arm Thread Guide, Lower	1	112715-0-01	
A-15- 5	Thread Guide Disc	2	144686-0-01		A-29	Screw	1	108960-0-04	
A-15- 6	Thread Guide Bracket	2	144687-0-01		A-30	Felt	1	114941-0-01	
A-15- 7	Nut	2	021670-1-02		A-31	Pipe	1	112714-0-00	
A-15- 8	Tension Control Nut	3	108265-0-01		A-32	Thread Release Shaft	1	144823-0-01	
A-15- 9	Tension Spring	2			A-33	Screw	2	151602-0-02	
A-15-10	Tension Disc Washer	2	108264-0-01		A-34	Arm Bed	1		
A-15-11	Tension Disc	4	108263-0-01		A-35	Needle Plate (Assembly)	1		
A-15-12	Thread Release Pin	1	144704-0-01		A-36	Screw	1	100032-0-03	
A-15-13	Thread Release Pin	1	144703-0-01		A-37	Pin	1	113386-0-00	
A-15-14	Tension Release Plate	1	144683-0-01		A-38	Screw	1	112751-0-02	
A-15-15	Spring	2	118320-0-01		A-39	Slide Plate, Left	1	112606-0-01	
A-15-16	Stud Screw	2	112712-0-01		A-40	Slide Plate, Right	1	112607-0-01	
A-15-17	Pin	2			A-41	Slide Plate Front Assembly	1	112610-0-01	
A-15-18	Pin	2			A-42	Screw	1	116010-0-01	



## B. Upper Shaft, Needle Bar and Rocking Mechanism

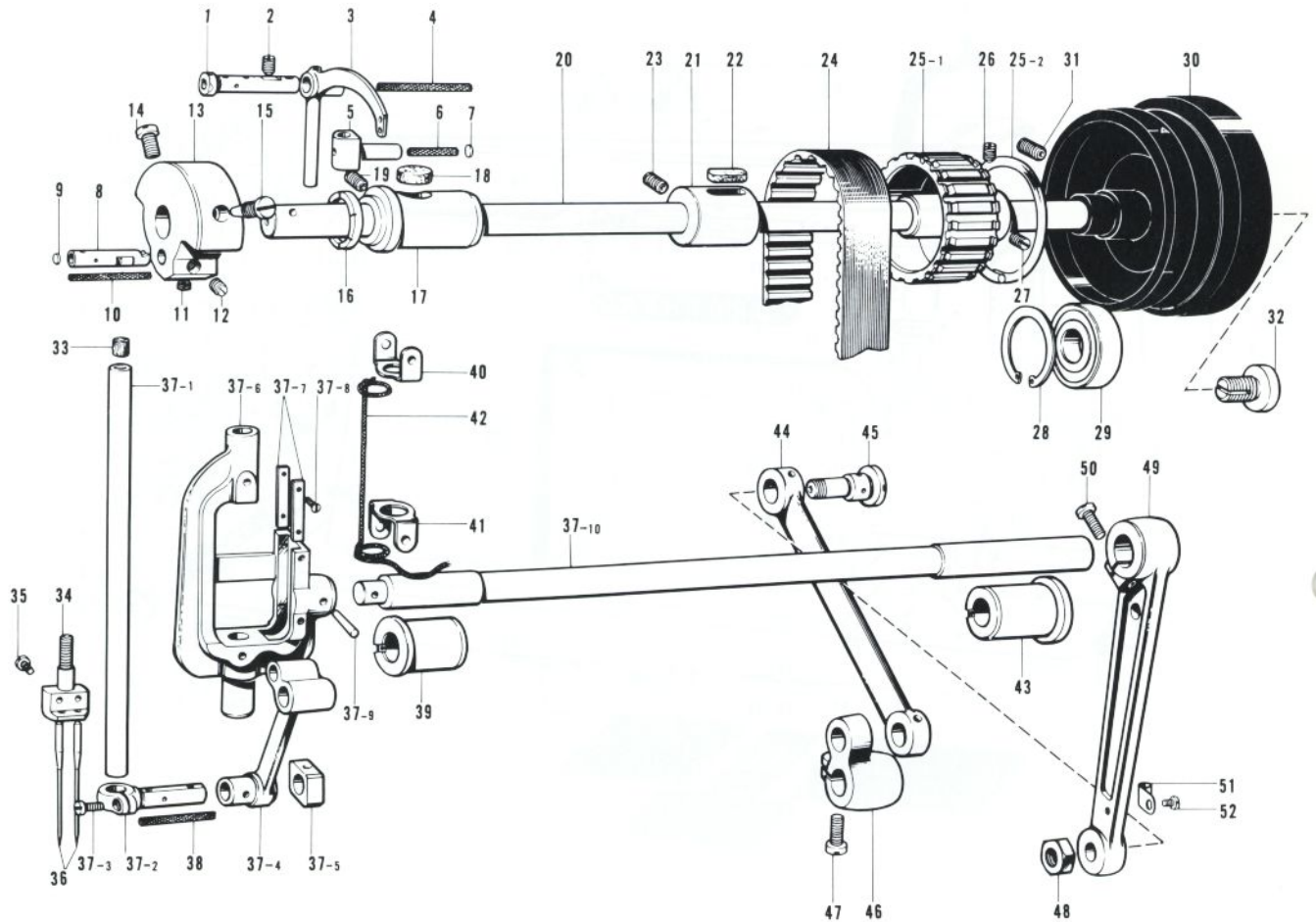

Ref. No.	Name of Parts	Q'ty	Parts No.	Assembly No.	Ref. No.	Name of Parts	Q'ty	Parts No.	Assembly No.
B-1	Stud	1	112579-0-01		B-31	Screw	2	013761-4-10	
B-2	Screw	1	151605-0-01		B-32	Screw	1	104478-0-01	
B-3	Thread Take-up Lever	1	112578-0-01		B-33	Needle Bar Cap	1	148394-0-00	
B-4	Wick 3φ x 45	1	112735-0-01		B-34	Needle Clamp	1		
B-5	Thread Take-up Lever Slide Block	1	118171-0-01		B-35	Screw	2	116323-0-01	
B-6	Wick	1	114693-0-01		B-36	Needle DP x 5	2		
B-7	Pusher	1	113024-0-00		B-37-1	Needle Bar	1	112591-0-01	
B-8	Needle Bar Crank	1	112577-0-01		B-37-2	Needle Bar Clamp	1	112592-0-01	
B-9	Pusher	1	113014-0-00		B-37-3	Screw	1	009670-8-12	
B-10	Wick 3φ x 45	1	112735-0-00		B-37-4	Needle Bar Crank Rod	1	112593-0-01	
B-11	Screw	1	101706-0-01		B-37-5	Needle Bar Guide Slide Block	1	112721-0-01	*B-37 Needle Bar Crank Rod Assembly 112587-1-01
B-12	Screw	1	100251-0-01		B-37-6	Needle Bar Support	1	112589-1-00	
B-13	Counter Weight	1	112574-0-00		B-37-7	Needle Bar Guide Plate	2	112590-0-01	
B-14	Screw	1	146141-0-01		B-37-8	Screw	4	102731-0-04	
B-15	Screw	1	100250-0-01		B-37-9	Pin	1	107030-0-01	
B-16	Thrust Ring	1	112576-0-01		B-37-10	Needle Bar Rock Shaft	1		
B-17	Upper Shaft Bushing, Left	1	112573-0-01		B-38	Wick	1	112728-0-01	
B-18	Felt	1	112734-0-01		B-39	Needle Bar Rock Shaft Bushing, Left	1	112594-0-01	
B-19	Screw	1	013761-4-10		B-40	Wick Presser (Upper)	1	112719-0-01	
B-20	Upper Shaft	1	112572-0-01		B-41	Wick Presser (Lower)	1	112720-0-01	
B-21	Upper Shaft Bushing, Center	1	114680-0-01		B-42	Wick	1	116699-0-00	
B-22	Felt	1	100248-0-01		B-43	Needle Bar Rock Shaft Bushing, Right	1	112764-0-01	
B-23	Screw	1	013761-4-10		B-44	Needle Bar Rock Link	1	112596-0-01	
B-24	Timing Belt	1	112586-0-01		B-45	Screw	2	112597-0-01	
B-25-1	Timing Belt Wheel Upper	1		B-25 Timing Belt Wheel Upper Assembly 180157-0-01	B-46	Needle Bar Connecting Crank	1	112598-0-01	
B-25-2	Side Ring	2			B-47	Screw	1	009781-8-12	
B-26	Screw	1	015771-2-12		B-48	Nut	2	101268-0-03	
B-27	Screw	1	013771-2-12		B-49	Needle Bar Connecting Rod	1	112595-0-00	
B-28	Stop Ring	1	112760-0-01		B-50	Screw	1	105351-0-02	
B-29	Ball Bearing	1	072620-4-60		B-51	Wick Support	1	112739-0-01	
B-30	Pulley	1	144614-0-01		B-52	Screw	1	009670-5-12	



## C. Presser Foot Mechanism

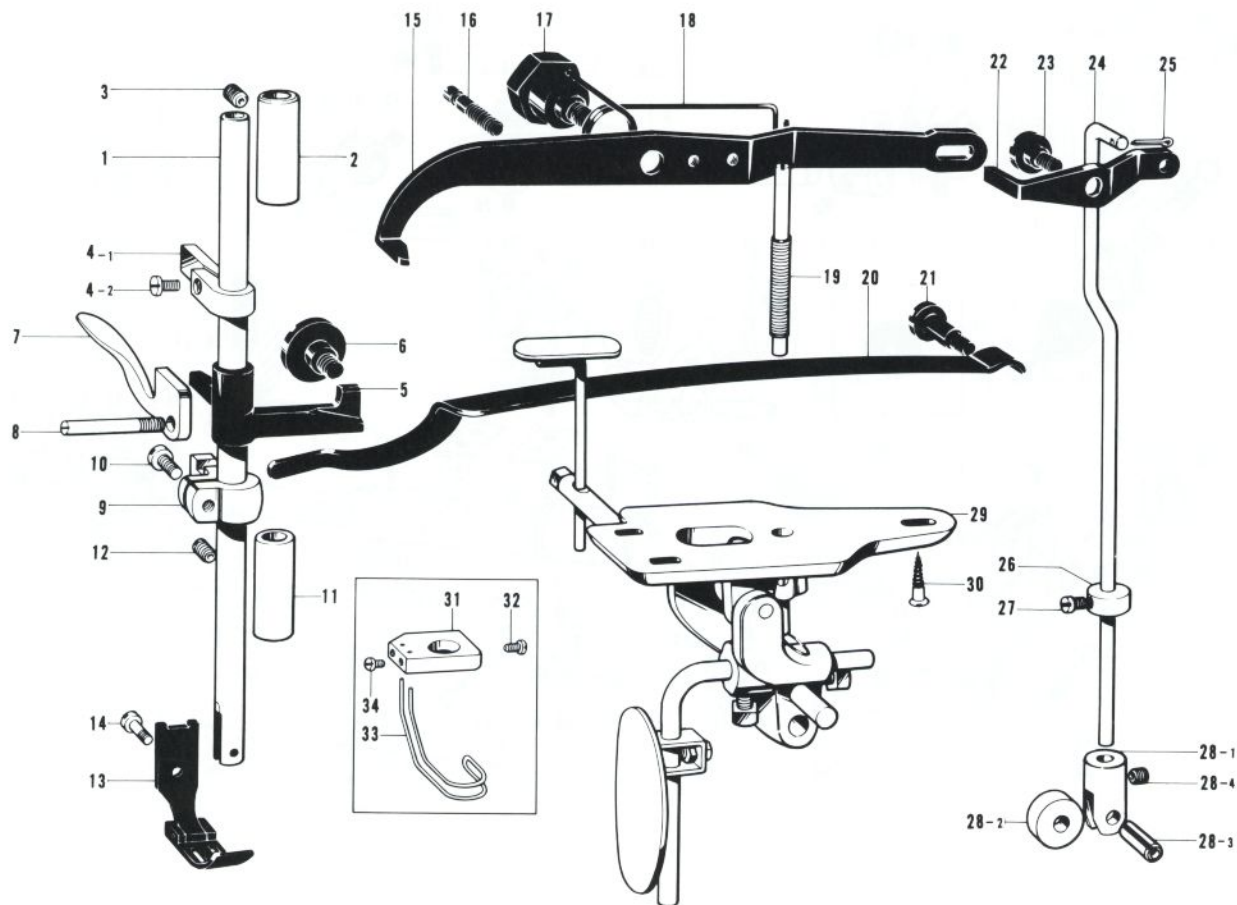

Ref. No.	Name of Parts	Q'ty	Parts No.	Assembly No.	Ref. No.	Name of Parts	Q'ty	Parts No.	Assembly No.
C- 1	Presser Bar	1	112614-0-01		C-19	Presser Adjusting Screw	1	112624-0-01	
C- 2	Presser Bar Bushing, Upper	1	112615-0-01		C-20	Presser Plate Spring	1	118170-0-01	
C- 3	Screw	1	100260-0-01		C-21	Screw	1	112623-0-01	
C- 4-1	Presser Bar Guide	1		C-4 Presser Bar Guide Assembly 180950-0-01	C-22	Knee Lifter Connecting Lever	1	112627-0-01	
C- 4-2	Screw	1	009680-7-12		C-23	Screw	1	112628-0-01	
C- 5	Presser Bar Lifter	1	148483-0-01		C-24	Knee Lifter Connecting Rod	1	112632-0-01	
C- 6	Presser Bar Lifter Guide	1	112631-0-01		C-25	Pin	1	114909-0-00	
C- 7	Presser Foot Lifter	1	112618-0-01		C-26	Collar	1	112634-0-02	
C- 8	Screw	1	112619-0-01		C-27	Screw	1	104908-0-04	
C- 9	Presser Bar Bracket	1	112616-0-01		C-28-1	Roller Bracket	1		C-28 Knee Lifter Roller Bracket 151609-0-01
C-10	Screw	1	009670-8-12		C-28-2	Roller	1	112636-0-01	
C-11	Presser Bar Bushing, Lower	1	112763-0-01		C-28-3	Pin	1	047501-2-42	
C-12	Screw	1	151604-0-01		C-28-4	Screw	1	151601-0-02	
C-13	Presser Foot	1			C-29	Knee Lifter Assembly	1	113380-0-01	
C-14	Screw	1	113050-0-01		C-30	Screw	3	106030-0-01	
C-15	Knee Lifter Lever	1	112625-0-01		C-31	Finger Guard Supporter	1	151191-0-01	
C-16	Stopper Screw	1	112630-0-01		C-32	Screw	1	144458-0-01	
C-17	Screw	1	112626-0-01		C-33	Finger Guard	1	150917-0-01	
C-18	Spring	1	112629-0-01		C-34	Screw	2	149177-0-01	

## D. Feed Mechanism

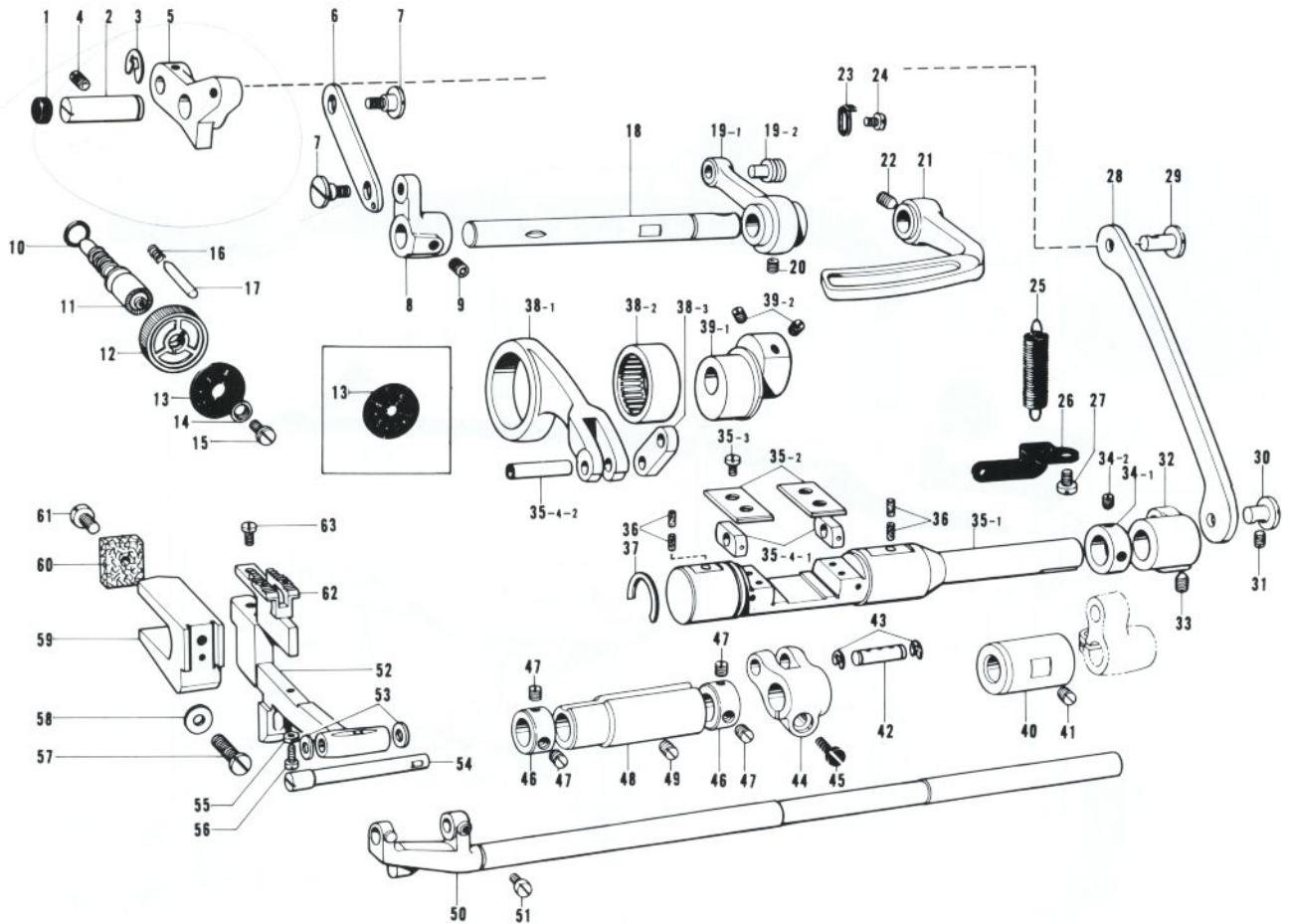

Ref. No.	Name of Parts	Q'ty	Parts No.	Assembly No.	Ref. No.	Name of Parts	Q'ty	Parts No.	Assembly No.
D- 1	Cap	1	143766-0-01		D-35-1	Feed Regulator Shaft	1		D-35
D- 2	Feed Regulator Stud	1	148488-0-01		D-35-2	Slide Block Guide Plate	2	143594-0-01	Feed Regulator Shaft Assembly
D- 3	Stop Ring	1	048070-3-42		D-35-3	Screw	4	009681-0-12	148771-0-01
D- 4	Screw	1	151605-0-01		D-35-4-1	Feed Regulator Slide Block	2		D-35-4
D- 5	Feed Regulator	1	148489-0-01		D-35-4-2	Feed Regulator Slide Block Shaft	1		Slide Block 145328-0-01
D- 6	Connecting Plate	1	118746-0-01		D-36	Felt	4	148743-0-01	
D- 7	Screw	2	112072-0-01		D-37	Stop Ring	1	143597-0-01	
D- 8	Lever	1	118747-0-01		D-38-1	Level Feed Connecting Rod	1	143612-0-00	D-38 Level Feed Connecting Rod Assembly
D- 9	Screw	1	118853-0-01		D-38-2	Needle Bearing	1	118954-0-00	143611-0-01
D-10	Packing	1	108549-0-01		D-38-3	Level Feed Connecting Link	1	143613-0-01	
D-11	Length Control Screw	1	143598-0-01		D-39-1	Eccentric Wheel	1		D-39
D-12	Length Control	1	153168-0-01		D-39-2	Screw	2	151605-0-01	Eccentric Wheel 148802-0-01
D-13	Length Control Plate	1	151508-0-01		D-40	Feed Rock Shaft Bushing, Right	1	148493-0-01	
D-14	Washer	1	142746-0-02		D-41	Screw	1	013761-4-10	
D-15	Screw	1	142747-0-02		D-42	Stud	1	143616-0-01	
D-16	Spring	1	100328-0-01		D-43	Stop Ring	2	048060-3-42	
D-17	Pin	1	145502-0-01		D-44	Lever Feed Arm	1	148495-0-01	
D-18	Feed Regulator Lever Shaft	1	151080-0-01		D-45	Screw	1	009781-8-12	
D-19-1	Link (B)	1		D-19 Link Assembly 143608-0-01	D-46	Collar	2	113074-0-01	
D-19-2	Spring Hook	1	108546-0-01		D-47	Screw	4	101706-0-01	
D-20	Screw	1	014760-6-22		D-48	Feed Rock Shaft Bushing, Left	1	148494-0-01	
D-21	Reverse Lever	1	118752-0-01		D-49	Screw	1	013761-4-10	
D-22	Screw	1	015771-0-12		D-50	Feed Rock Shaft	1	149001-0-01	
D-23	Reverse Lever Stopper	1	118865-0-01		D-51	Screw	1	104908-0-04	
D-24	Screw	1	009680-7-12		D-52	Feed Bar	1	151081-0-01	
D-25	Spring	1	143609-0-01		D-53	Thrust Ring	2	143591-0-01	
D-26	Spring Hook Plate	1	143610-0-01		D-54	Feed Bar Shaft	1	148977-0-01	
D-27	Screw	1	009710-8-12		D-55	Nut	1	021660-1-03	
D-28	Feed Regulator Connecting Link	1	148487-0-01		D-56	Screw	1	107278-0-02	
D-29	Pin	1	118713-0-01		D-57	Screw	1	009761-4-12	
D-30	Pin	1	148501-0-01		D-58	Washer	1	025060-1-32	
D-31	Screw	2	151602-0-01		D-59	Feed Bar Fork	1	112656-0-01	
D-32	Feed Regulator Arm	1	148499-0-01		D-60	Felt	1	112759-0-01	
D-33	Screw	1	118853-0-01		D-61	Screw	1	100242-0-03	
D-34-1	Collar	1		D-34 Collar Assembly 180321-0-01	D-62	Feed Dog	1		
D-34-2	Screw	2	101706-0-01		D-63	Screw	2	116283-0-01	



## E. Lower Shaft, Rotary Hook Mechanism

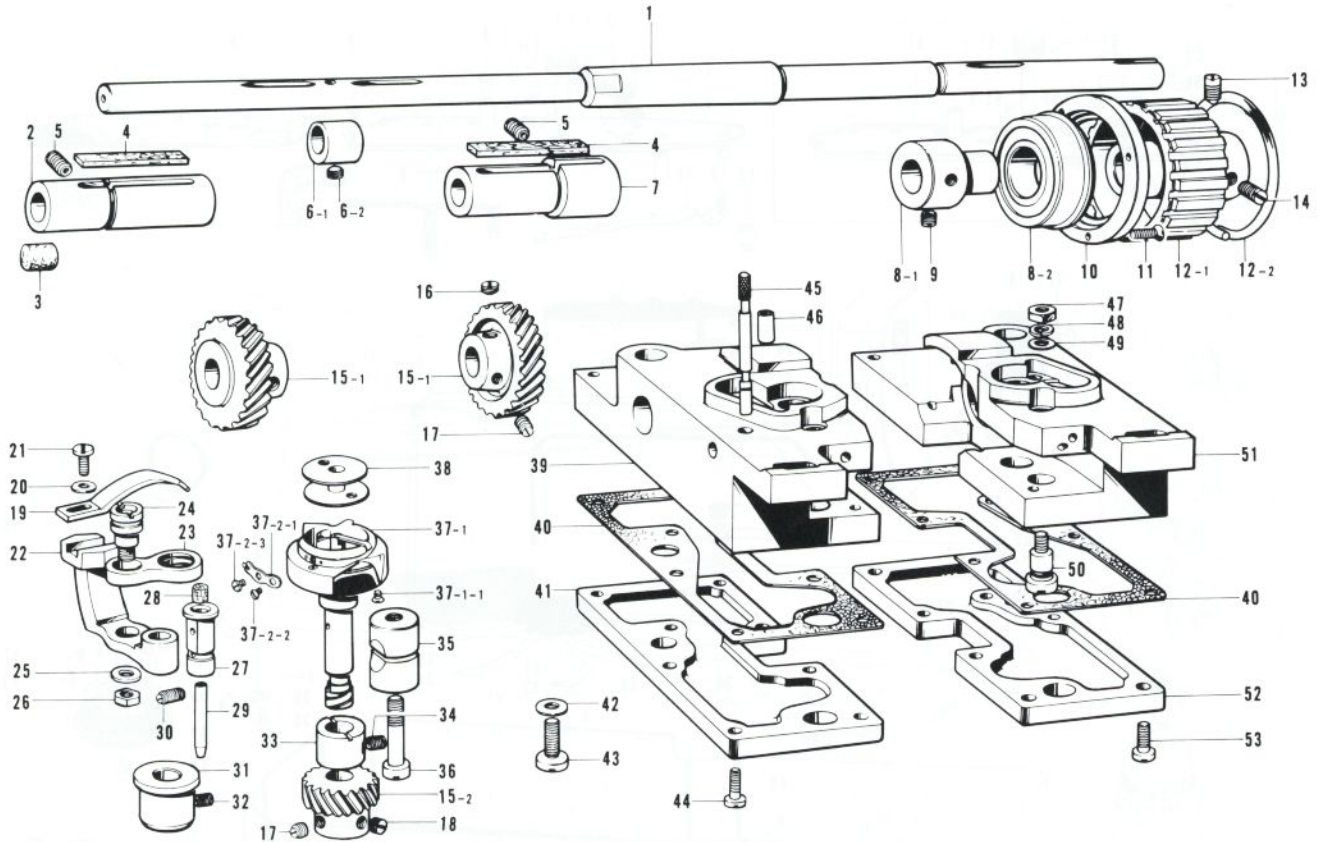

Ref. No.	Name of Parts	Q'ty	Parts No.	Assembly No.	Ref. No.	Name of Parts	Q'ty	Parts No.	Assembly No.
E- 1	Lower Shaft	1	151082-0-01		E-27	Opener Crank Stud	2	112695-0-01	
E- 2	Rotary Hook Base Bushing, Left	1	148503-0-00		E-28	Felt	2	107155-0-01	
E- 3	Felt	1	115249-0-01		E-29	Pipe	1	112696-0-00	
E- 4	Felt	2	113362-0-01		E-30	Screw	2	153483-0-01	
E- 5	Screw	2	151604-0-01		E-31	Rotary Hook Shaft Bushing, Lower	2	112687-0-01	
E- 6-1	Vertical Feed Eccentric Wheel	1		E-6 Vertical Feed Eccentric Wheel Assembly 181486-0-01	E-32	Screw	2	107794-0-01	
E- 6-2	Screw	1	112684-0-01		E-33	Rotary Hook Shaft Bushing, Upper	2	112690-0-01	
E- 7	Rotary Hook Base Bushing, Right	1	148502-0-00		E-34	Screw	2	107794-0-01	
E- 8-1	Ball Bearing	1	112666-0-00		E-35	Pinch Sleeve	2	112699-0-01	
E- 8-2	Bushing	1	112667-0-01	E-8 Bearing Holder Assembly 112698-0-01	E-36	Screw	2	112700-0-01	
E- 9	Screw	2	013780-7-10		E-37-1	Outer Rotary Hook Assembly	2		E-37 Rotary Hook 112691-0-01
E-10	Bearing Presser	1	112668-0-01		E-37-1-1	Screw	4	151028-0-01	
E-11	Screw	3	005671-2-12		E-37-2-1	Adjusting Spring	2	151145-0-01	E-37-2 Inner Rotary Hook Assembly 151138-0-01
E-12-1	Trimming Belt Wheel Lower	1		E-12 Timing Belt Wheel Lower Assembly 180164-0-01	E-37-2-2	Screw	2	151029-0-01	
E-12-2	Ring	1			E-37-2-3	Screw	2	151030-0-01	
E-13	Screw	1	015771-2-12		E-38	Bobbin	2	112781-0-01	
E-14	Screw		013771-2-12		E-39	Rotary Hook Base, Left	1	112685-0-01	
E-15-1	Spiral Gear	2		E-15 Spiral Gear Assembly 180949-0-01	E-40	Packing	2	112755-0-01	
E-15-2	Pinion	2			E-41	Oil Reservoir, Left	1	112686-0-01	
E-16	Screw	2	112684-0-01		E-42	Washer	2	100197-0-02	
E-17	Screw	4	100251-0-01		E-43	Screw	2	105351-0-02	
E-18	Screw	6	101706-0-01		E-44	Screw	8	100032-0-02	
E-19	Bobbin Case Opener	2	112697-0-01		E-45	Oil Gauge	2	112757-0-01	
E-20	Washer	2	105161-0-02		E-46	Oil Pipe	2	115287-0-00	
E-21	Screw	2	009670-8-12		E-47	Nut	2	105234-0-01	
E-22	Opener Crank	2	112694-0-01		E-48	Washer	2	028680-2-43	
E-23	Opener Link	2	112692-0-01		E-49	Washer	2	100645-0-03	
E-24	Opener Link Stud	2	148005-0-01		E-50	Oil Adjusting Screw	2	112756-0-01	
E-25	Washer	2	025710-2-32		E-51	Rotary Hook Base, Right	1	112701-0-01	
E-26	Nut	2	110161-0-06		E-52	Rotary Hook Base Oil Reservoir, Right	1	112702-0-01	
					E-53	Screw	8	100320-0-02	

# G. -400 · -500 Specification

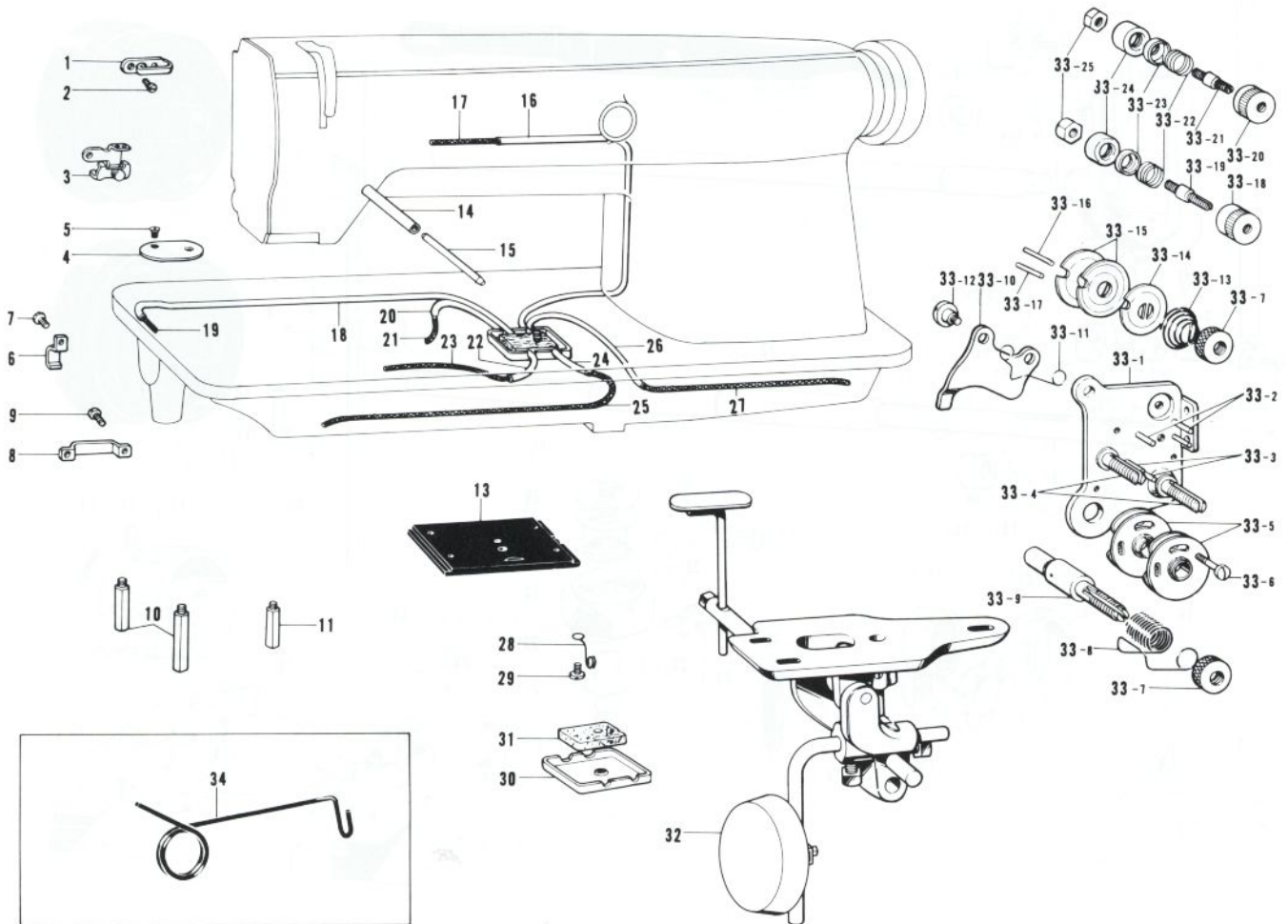

Ref. No.	Name of Parts	Q'ty	Parts No.	Assembly No.	Ref. No.	Name of Parts	Q'ty	Parts No.	Assembly No.
G- 1	Arm Thread Guide, Center	1	112658-0-01		G-31	Felt	1	148732-0-01	
G- 2	Screw	1	108960-0-04		G-32	Knee Lifter Assembly	1	148674-0-01	
G- 3	Thread Guide Assembly	1	148656-0-01		G-33- 1	Upper Thread Tension Plate	1		
G- 4	Cover	1	148614-0-01		G-33- 2	Pin	3		
G- 5	Screw	2	149288-0-01		G-33- 3	Pin	2		
G- 6	Tube Holder		142268-0-01		G-33- 4	Tension Stud	2		
G- 7	Screw		009670-6-12		G-33- 5	Spring Guide	2	108254-0-01	
G- 8	Cord Holder	1	148818-0-01		G-33- 6	Screw	1	144682-0-01	
G- 9	Screw	2	009670-6-12		G-33- 7	Tension Control Nut	3	108265-0-01	
G-10	Bed Leg	2	148611-0-01		G-33- 8	Thread Take-up Spring	1	144681-0-01	
G-11	Bed Leg Small	1	149179-0-01		G-33- 9	Tension Stud	1	144680-0-01	
G-13	Slide Plate Front Assembly	1	148599-0-01		G-33-10	Tension Release Plate	1	144683-0-01	
G-14	Pipe	1	148604-0-00		G-33-11	Arm Thread Guide Upper	1	118320-0-01	
G-15	Tension Release Bar	1	148610-0-01		G-33-12	Screw	2	112712-0-01	G-33
G-16	Oil Tube	1	148730-0-01		G-33-13	Tension Spring	2		Tension
G-17	Wick 2.5φ × 720	1	148731-0-00		G-33-14	Tension Disc Washer	2	148669-0-01	Control
G-18	Oil Tube	1	148741-0-01		G-33-15	Tension Disc	4	108263-0-01	Plate
G-19	Wick 2.5φ × 375	1	148742-0-00		G-33-16	Tension Release Pin	1	148671-0-01	Assembly
G-20	Oil Tube	1	148733-0-01		G-33-17	Tension Release Pin	1	148670-0-01	
G-21	Wick 2.5φ × 160	1	148740-0-00		G-33-18	Adjusting Screw (B)	1	148665-0-01	
G-22	Oil Tube	1	148735-0-01		G-33-19	Thread Guide Screw (B)	1	148663-0-01	
G-23	Wick 2.5φ × 300	1	148736-0-00		G-33-20	Adjusting Screw (A)	1	148664-0-01	
G-24	Oil Tube	1	148737-0-01		G-33-21	Thread Guide Screw (A)	1	148662-0-01	
G-25	Wick 2.5φ × 335	1	148738-0-00		G-33-22	Thread Guide Spring	2	148668-0-01	
G-26	Oil Tube	1	148733-0-01		G-33-23	Thread Guide Disc	2	148667-0-01	
G-27	Wick 2.5φ × 310	1	148734-0-00		G-33-24	Thread Guide Bracket	2	148666-0-01	
G-28	Tube Holder	1	112745-0-01		G-33-25	Nut	2	021670-1-02	
G-29	Screw	1	009670-5-12		G-34	Spring	1	149768-0-01	
G-30	Oil Tube Supporter	1	148729-0-01						



# G. -400 · -500 Specification

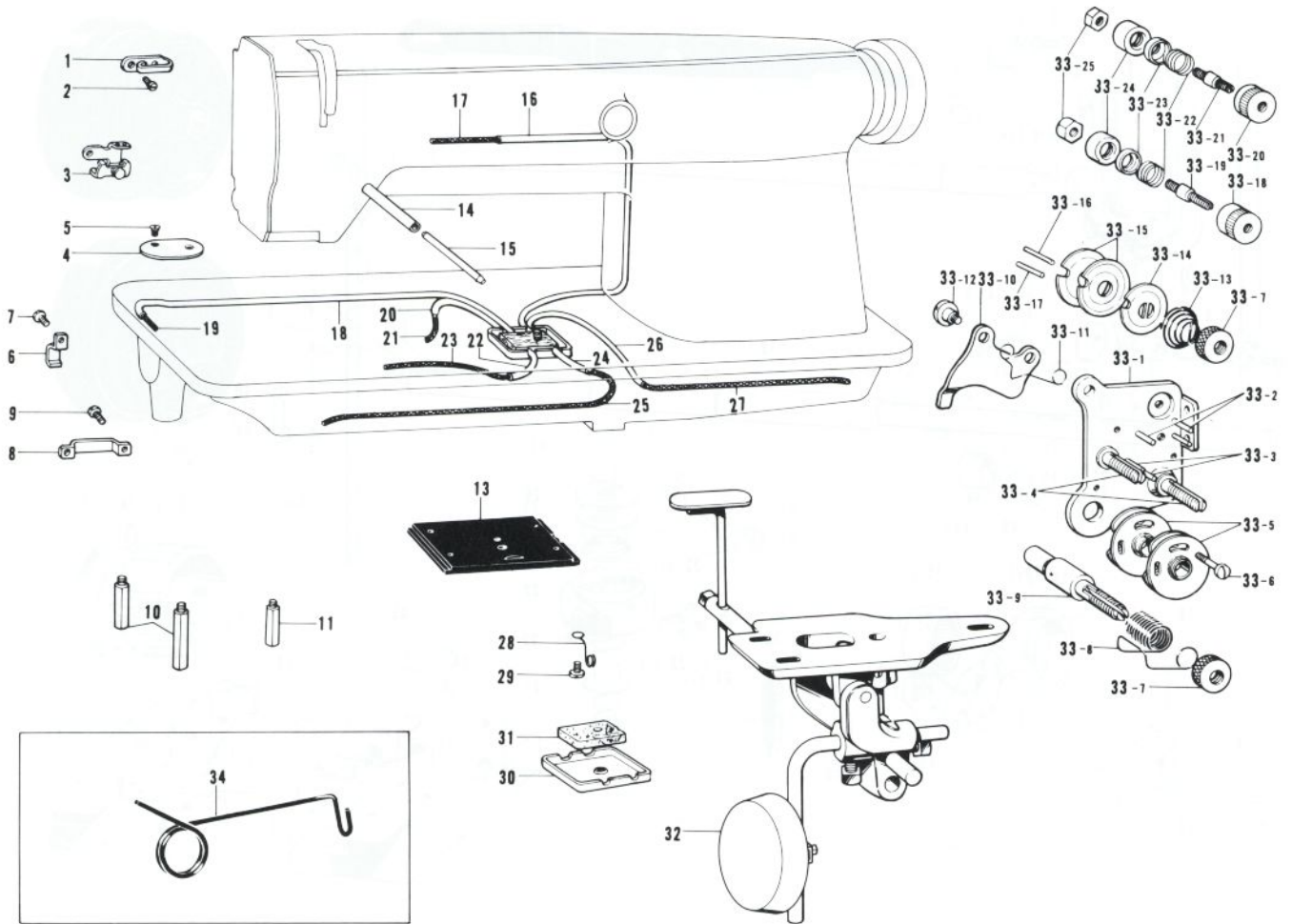

Ref. No.	Name of Parts	Q'ty	Parts No.	Assembly No.	Ref. No.	Name of Parts	Q'ty	Parts No.	Assembly No.
G- 1	Arm Thread Guide, Center	1	112658-0-01		G-31	Felt	1	148732-0-01	
G- 2	Screw	1	108960-0-04		G-32	Knee Lifter Assembly	1	148674-0-01	
G- 3	Thread Guide Assembly	1	148656-0-01		G-33- 1	Upper Thread Tension Plate	1		
G- 4	Cover	1	148614-0-01		G-33- 2	Pin	3		
G- 5	Screw	2	149288-0-01		G-33- 3	Pin	2		
G- 6	Tube Holder		142268-0-01		G-33- 4	Tension Stud	2		
G- 7	Screw		009670-6-12		G-33- 5	Spring Guide	2	108254-0-01	
G- 8	Cord Holder	1	148818-0-01		G-33- 6	Screw	1	144682-0-01	
G- 9	Screw	2	009670-6-12		G-33- 7	Tension Control Nut	3	108265-0-01	
G-10	Bed Leg	2	148611-0-01		G-33- 8	Thread Take-up Spring	1	144681-0-01	
G-11	Bed Leg Small	1	149179-0-01		G-33- 9	Tension Stud	1	144680-0-01	
G-13	Slide Plate Front Assembly	1	148599-0-01		G-33-10	Tension Release Plate	1	144683-0-01	
G-14	Pipe	1	148604-0-00		G-33-11	Arm Thread Guide Upper	1	118320-0-01	
G-15	Tension Release Bar	1	148610-0-01		G-33-12	Screw	2	112712-0-01	G-33
G-16	Oil Tube	1	148730-0-01		G-33-13	Tension Spring	2		Tension
G-17	Wick 2.5φ x 720	1	148731-0-00		G-33-14	Tension Disc Washer	2	148669-0-01	Control
G-18	Oil Tube	1	148741-0-01		G-33-15	Tension Disc	4	108263-0-01	Plate
G-19	Wick 2.5φ x 375	1	148742-0-00		G-33-16	Tension Release Pin	1	148671-0-01	Assembly
G-20	Oil Tube	1	148733-0-01		G-33-17	Tension Release Pin	1	148670-0-01	
G-21	Wick 2.5φ x 160	1	148740-0-00		G-33-18	Adjusting Screw (B)	1	148665-0-01	
G-22	Oil Tube	1	148735-0-01		G-33-19	Thread Guide Screw (B)	1	148663-0-01	
G-23	Wick 2.5φ x 300	1	148736-0-00		G-33-20	Adjusting Screw (A)	1	148664-0-01	
G-24	Oil Tube	1	148737-0-01		G-33-21	Thread Guide Screw (A)	1	148662-0-01	
G-25	Wick 2.5φ x 335	1	148738-0-00		G-33-22	Thread Guide Spring	2	148668-0-01	
G-26	Oil Tube	1	148733-0-01		G-33-23	Thread Guide Disc	2	148667-0-01	
G-27	Wick 2.5φ x 310	1	148734-0-00		G-33-24	Thread Guide Bracket	2	148666-0-01	
G-28	Tube Holder	1	112745-0-01		G-33-25	Nut	2	021670-1-02	
G-29	Screw	1	009670-5-12		G-34	Spring	1	149768-0-01	
G-30	Oil Tube Supporter	1	148729-0-01						

# H. -400 - 500 Specification

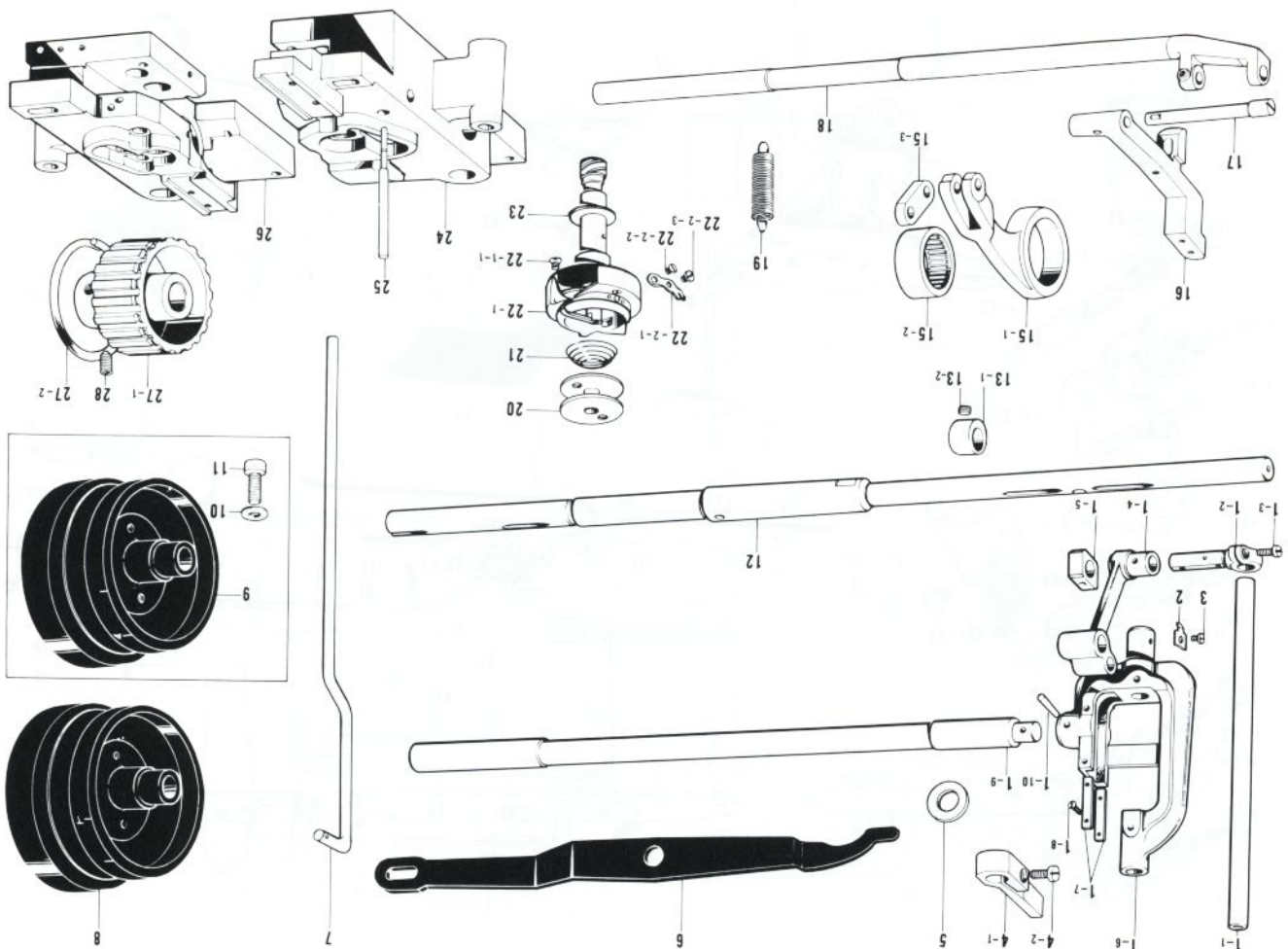

Ref. No.	Name of Parts	Qty	Parts No.	Assembly No.	Ref. No.	Name of Parts	Qty	Parts No.	Assembly No.
H-1-1	Needle Bar	1	148597-0-01		H-1-1	Level Feed Connecting Rod	1	148496-0-00	H-15 Level Feed Connecting Rod Assembly 148801-0-01
H-1-2	Needle Bar Clamp	1	112592-0-01		H-1-2	Needle Bearing	1	118954-0-00	
H-1-3	Screw	1	009670-8-12		H-1-3	Level Feed Connecting Link	1	143613-0-01	
H-1-4	Needle Bar Crank Rod	1	112593-0-01		H-1-4	Feed Bar	1	148490-0-01	
H-1-5	Needle Bar Guide Slide Block	1	11271-0-01		H-1-5	Feed Bar Shaft	1	148491-0-01	
H-1-6	Needle Bar Support	1	148596-1-00		H-1-6	Feed Rock Shaft	1	148492-0-01	
H-1-7	Needle Bar Guide Plate	2	112590-0-01		H-1-7	Spring	1	148726-0-01	
H-1-8	Screw	4	102731-0-04		H-1-8	Bobbin	2	148603-0-01	
H-1-9	Needle Bar Rock Shaft	1	107030-0-01		H-1-9	Bobbin Tension Spring	2		
H-1-10	Pin	1	148598-0-01		H-21	Outer Rotary Hook Assembly	2		
H-2	Needle Bar Indicator	1	148598-0-01		H-22-1	Screw	4	151028-0-01	H-22 Rotary Hook
H-3	Screw	1	105288-0-01		H-22-2-1	Adjusting Spring	2	151145-0-01	
H-4-1	Presser Bar Guide	1			H-22-2-2	Screw	2	151029-0-01	H-22-2 Inner Rotary Hook Assembly 151144-0-01
H-4-2	Screw	1	009680-7-12	H-4 Presser Bar Guide 148835-0-01	H-22-2-3	Screw	2	151030-0-01	
H-5	Collar	1	148605-0-01		H-23	Spacer 0.2	4	153243-0-01	
H-6	Knee Lifter Lever	1	148486-0-01		H-23	Spacer 0.3	2	153244-0-01	
H-7	Knee Lifter Connecting Rod	1	148484-0-01		H-24	Rotary Hook Base, Left	1	148481-0-01	
H-8	Pulley	1	148617-0-01		H-25	Oil Gauge	2	148728-0-01	
H-9	Pulley	1	149062-0-01		H-26	Rotary Hook Base, Right	1	148480-0-01	
H-10	Washer	2	025770-2-32		H-27-1	Timing Belt Wheel Lower	1		H-27 Timing Belt Pulley Lower Assembly 148803-0-01
H-11	Bolt	2	149569-0-01		H-27-2	Ring	1		
H-12	Lower Shaft	1	148505-0-01		H-28	Screw	1	148821-0-01	
H-13-1	Vertical Feed Eccentric Wheel	1							
H-13-2	Screw	1	112684-0-01	H-13 Vertical Feed Eccentric Wheel Assembly 148804-0-01					



# J. -400 · -500 Specification

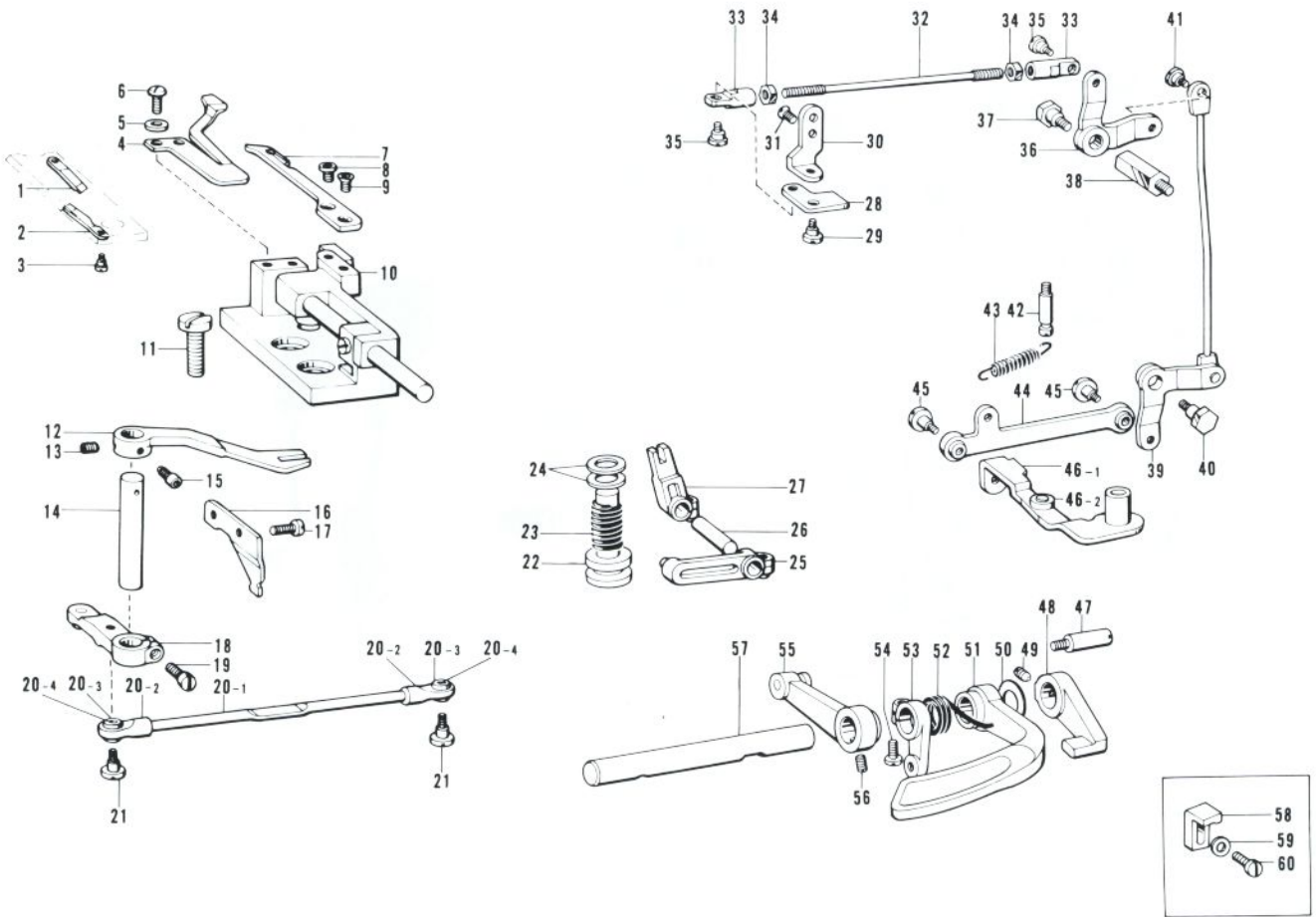

Ref. No.	Name of Parts	Q'ty	Parts No.	Assembly No.	Ref. No.	Name of Parts	Q'ty	Parts No.	Assembly No.
J- 1	Fixed Knife, Right	1	149169-0-01		J-31	Screw	2	117160-0-01	
J- 2	Fixed Knife, Left	1	148538-0-01		J-32	Tension Release Rod Upper	1	148631-0-01	
J- 3	Stud Screw	2	148539-0-01		J-33	Joint	2	148632-0-01	
J- 4	Thread Presser Spring	2			J-34	Nut	2	021670-1-02	
J- 5	Washer	4	025630-1-32		J-35	Stud Screw	2	148768-0-01	
J- 6	Screw	4	001630-4-02		J-36	Tension Release Crank Upper	1	148630-0-01	
J- 7	Movable Knife	2	148535-0-01		J-37	Screw	1	148628-0-01	
J- 8	Screw	2	148536-0-01		J-38	Stud	1	148629-0-01	
J- 9	Screw	2	148537-0-01		J-39	Tension Release Crank Lower	1	148625-0-01	
J-10	Movable Knife Base Assembly	2	148531-0-01		J-40	Screw	1	148628-0-01	
J-11	Screw	4	009710-8-12		J-41	Screw	1	110171-0-01	
J-12	Knife Rock Arm	2	148572-0-01		J-42	Spring Hanger	1	115177-0-01	
J-13	Screw	2	014770-6-22		J-43	Spring	1	148654-0-01	
J-14	Knife Rock Arm Shaft	2	148573-0-01		J-44	Tension Release Connecting Rod Lower	1	148623-0-01	
J-15	Screw	2	148574-0-01		J-45	Stud Screw	2	123882-0-01	
J-16	Spring Hook, Left	1	148580-0-01		J-46-1	Tension Release Rock Lever	1		J-46 Tension Release Rock Lever Assembly 148619-0-01
J-17	Screw	2	009711-0-12		J-46-2	Tension Release Roller Stud Assembly	1		
J-18	Knife Rock Lever, Left	1	148577-0-01		J-47	Screw	1	141748-0-01	
J-19	Screw	1	009711-4-12		J-48	Reverse Lever (B)	1	148607-0-01	
J-20-1	Knife Connecting Bar	1		J-20 Connecting Rod Assembly 148585-0-01	J-49	Screw	1	015771-0-12	
J-20-2	Joint	2	148584-0-01		J-50	Thrust Ring	1	149554-0-01	
J-20-3	Bushing	2			J-51	Reverse Lever (B)	1	148606-0-01	
J-20-4	Pin	2			J-52	Spring	1	148608-0-01	
J-21	Screw	2	141494-0-01		J-53	Reverse Lever Shaft Arm	1	148640-0-01	
J-22	Knife Main Lever Shaft	1	148547-0-01		J-54	Screw	1	009711-4-12	
J-23	Spring	1	148555-0-01		J-55	Feed Regulator Link	1	148638-0-01	
J-24	Rubber	2	148559-0-00		J-56	Screw	1	014760-6-22	
J-25	Knife Driving Pin Lever	1	181712-0-01		J-57	Reverse Lever Shaft	1	148609-0-01	
J-26	Knife Driving Lever Shaft	1	148557-0-01		J-58	Stopper	1	149282-0-01	
J-27	Knife Driving	1	181713-0-01		J-59	Washer	1	100645-0-03	
J-28	Tension Release Crank	1	148635-0-01		J-60	Screw	1	009681-0-12	
J-29	Screw	1	148633-0-01						
J-30	Tension Release Plate	1	148634-0-01						

## K. Thread Wiper, Reverse Switch Mechanism -400 · -500 Specification

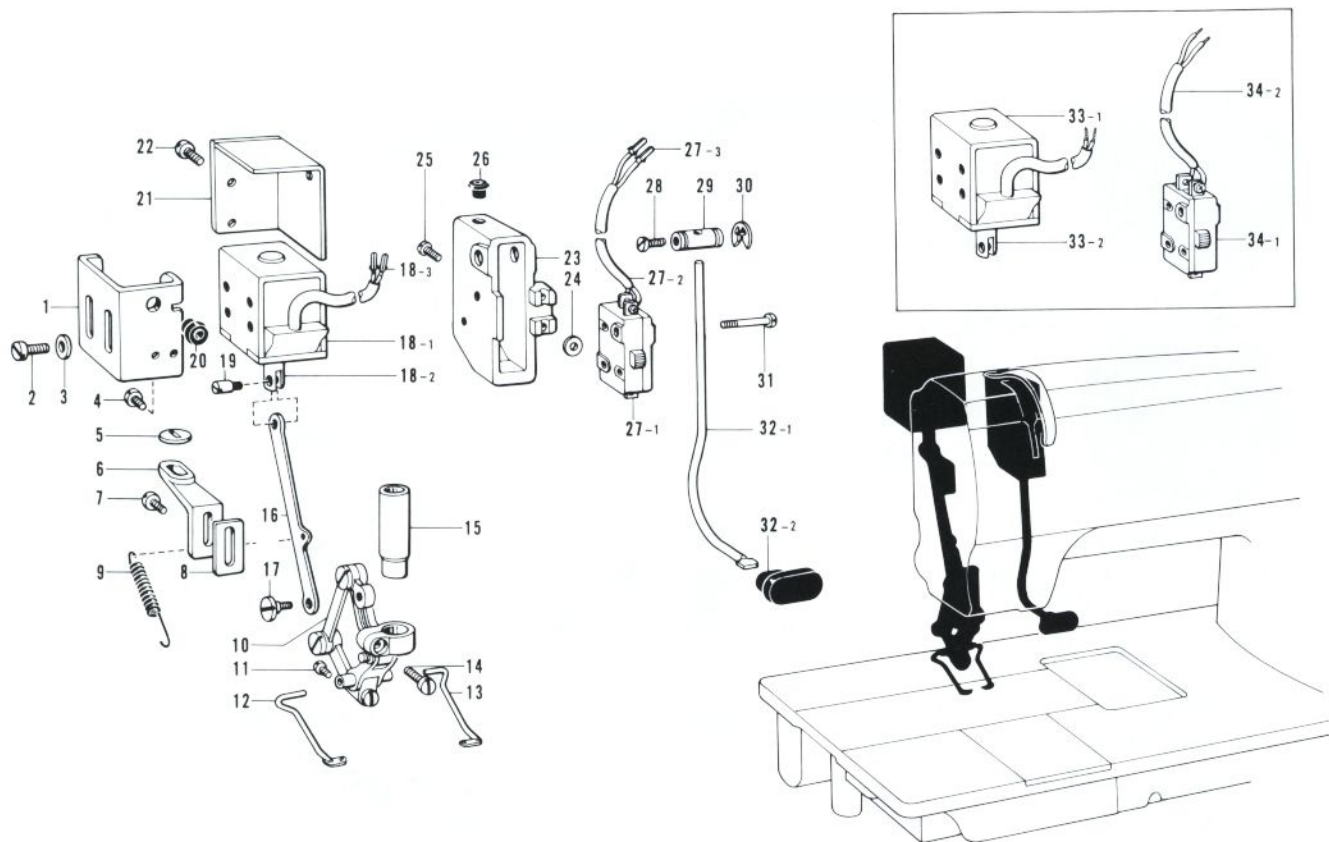

Ref. No.	Name of Parts	Q'ty	Parts No.	Assembly No.	Ref. No.	Name of Parts	Q'ty	Parts No.	Assembly No.
K- 1	Solenoid Bracket	1	148513-0-01		K-20	Bushing	1	146080-0-00	
K- 2	Screw	4	007401-0-13		K-21	Solenoid Cover	1	148514-0-01	
K- 3	Washer	4	025040-2-33		K-22	Screw	3	009679-3-12	
K- 4	Screw	2	107407-0-03		K-23	Micro Switch Base	1	146120-0-01	
K- 5	Stopper	1	148518-0-00		K-24	Washer	2	403616-0-01	
K- 6	Stopper	1	148516-0-01		K-25	Screw	2	009671-0-12	
K- 7	Screw	2	107407-0-03		K-26	Bushing	1	146080-0-00	
K- 8	Stopper	1	148517-0-00		K-27-1	Micro Switch	1		K-27 Switch 151884-0-00
K- 9	Spring	1			K-27-2	Reverse Switch Cord	1		
K-10	Thread Wiper Link	1	148770-0-01		K-27-3	Terminal Pin	2	143549-0-00	
K-11	Screw	2	149177-0-01		K-28	Screw	1	009681-4-14	
K-12	Thread Wiper, Left	1	148530-0-01		K-29	Actuator Pin	1	146125-0-01	
K-13	Thread Wiper, Right	1	148529-0-01		K-30	Stop Ring	2	048080-3-42	
K-14	Screw	1	009711-4-13		K-31	Screw	2	146124-0-01	
K-15	Presser Bar Bushing Lower	1	148508-0-01		K-32-1	Actuator Bar	1	148613-0-01	K-32 Actuator Assembly 148612-0-01
K-16	Solenoid Link	1	148515-0-01		K-32-2	Actuator	1	146128-0-00	
K-17	Screw	1	148521-0-01		K-33-1	Solenoid	1		K-33 Thread Wiper Solenoid 149246-0-01
K-18-1	Solenoid	1		K-18 Thread Wiper Solenoid 148509-0-01	K-33-2	Plunger	1	148511-0-01	
K-18-2	Plunger	1	148511-0-01			K-34-1	Micro Switch	1	
K-18-3	Terminal Pin	2	143549-0-00		K-34-2	Reverse Switch Cord	1		
K-19	Plunger Pin	1	148546-0-01						



# L. -400 Specification

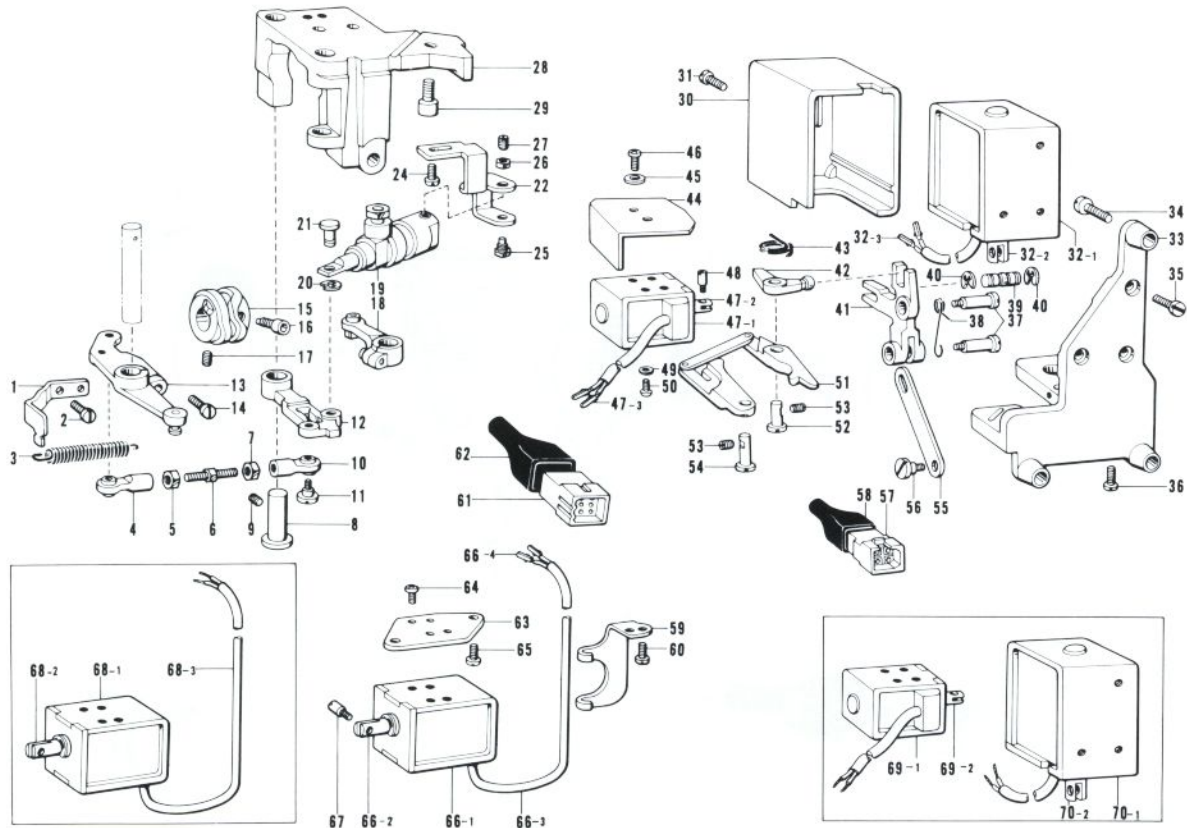

Ref. No.	Name of Parts	Q'ty	Parts No.	Assembly No.	Ref. No.	Name of Parts	Q'ty	Parts No.	Assembly No.
L-1	Spring Rock, Right	1	148579-0-01		L-40	Stop Ring	2	048040-3-42	
L-2	Screw	2	009711-0-12		L-41	Reverse Crank	1	148642-0-01	
L-3	Spring				L-42	Stopper Lever	1	148765-0-01	
L-4	Joint Assembly, Left	1	148589-0-01		L-43	Spring	1	148653-0-01	
L-5	Nut	1	100022-0-05		L-44	Solenoid Cover	1	148744-0-01	
L-6	Connecting Screw	1	148591-0-01		L-45	Washer	2	025030-2-32	
L-7	Nut	1	148592-0-01		L-46	Screw	2	002300-5-05	
L-8	Knife Sub Lever Shaft	1	148554-0-01		L-47-1	Solenoid	1		L-47 "O" Reset Solenoid Assembly 148648-0-01
L-9	Screw	1	100289-0-03		L-47-2	Plunger	1	148650-0-01	
L-10	Joint Assembly, Right	1	148587-0-01		L-47-3	Terminal Pin	2	143549-0-00	
L-11	Screw	2	141494-0-01		L-48	Plunger Pin	1	148651-0-01	
L-12	Knife Sub Lever	1	148553-0-01		L-49	Washer	4	025030-2-33	
L-13	Knife Rock Lever Right Assembly	1	148575-0-01		L-50	Screw	4	002300-6-03	
L-14	Screw	1	009711-4-12		L-51	Stopper	1	148763-0-01	
L-15	Knife Driving Cam	1			L-52	Pin	1	118713-0-01	
L-16	Screw	1	148574-0-01		L-53	Screw	2	151602-0-02	
L-17	Screw	1	014770-6-22		L-54	Stopper (A) Shaft	1	148767-0-01	
L-18	Knife Main Lever	1	148548-0-01		L-55	Reverse Link	1	148641-0-01	
L-19	Damper	1	148562-0-01		L-56	Screw	1	110171-0-01	
L-20	Stop Ring	1	048030-3-42		L-57	6P Connector	1	146118-0-00	
L-21	Damper Stud	1	148567-0-01		L-58	Connector Cap	1	145596-0-01	
L-22	Cylinder Holder	1	148568-0-01		L-59	Cord Holder	1	148655-0-01	
L-24	Screw	2	009781-4-12		L-60	Screw	2	009710-8-12	
L-25	Screw	2	140620-0-01		L-61	Nylon Connector	1	145681-0-00	
L-26	Nut	1	100078-0-03		L-62	Connector Cap	1	146119-0-00	
L-27	Screw	1	011802-0-12		L-63	Solenoid Bracket	1	148561-0-01	
L-28	Movable Knife Base Bracket	1	148482-0-01		L-64	Screw	4	002400-8-03	
L-29	Bolt	3	018061-6-22		L-65	Screw	2	009711-0-12	
L-30	Solenoid Cover	1	148560-0-01		L-66-1	Thread Trimmer Solenoid	1		L-66 Thread Trimmer Solenoid Assembly 148542-0-01
L-31	Screw	1	007500-6-02		L-66-2	Plunger	1	148545-0-01	
L-32-1	Solenoid	1		L-32 Reverse Solenoid Assembly 148636-0-01	L-66-3	Solenoid Cord	1		
L-32-2	Plunger	1	148637-0-01		L-66-4	Terminal Pin	2	143549-0-00	
L-32-3	Terminal Pin	2	143549-0-00		L-67	Plunger Pin	1	148546-0-01	
L-33	Reverse Solenoid Bracket	1	148643-0-01		L-68-1	Thread Trimmer Solenoid	1		L-68 Thread Trimmer Solenoid Assembly 149245-0-01
L-34	Screw	3	009782-5-12		L-68-2	Plunger	1	148545-0-01	
L-35	Screw	3	007500-8-02		L-68-3	Solenoid Cord	1		
L-36	Screw	1	107419-0-02		L-69-1	Solenoid	1		L-69 "O" Reset Solenoid Assembly 149244-0-01
L-37	Screw	2	148764-0-01		L-69-2	Plunger	1	148650-0-01	
L-38	Spring	1	148652-0-01		L-70-1	Solenoid	1		L-70 Reverse Solenoid Assembly 149243-0-01
L-39	Connecting Pin	1	149174-0-01		L-70-2	Plunger	1	148637-0-01	

# M. Synchronizer Mechanism -400 · -500 Specification

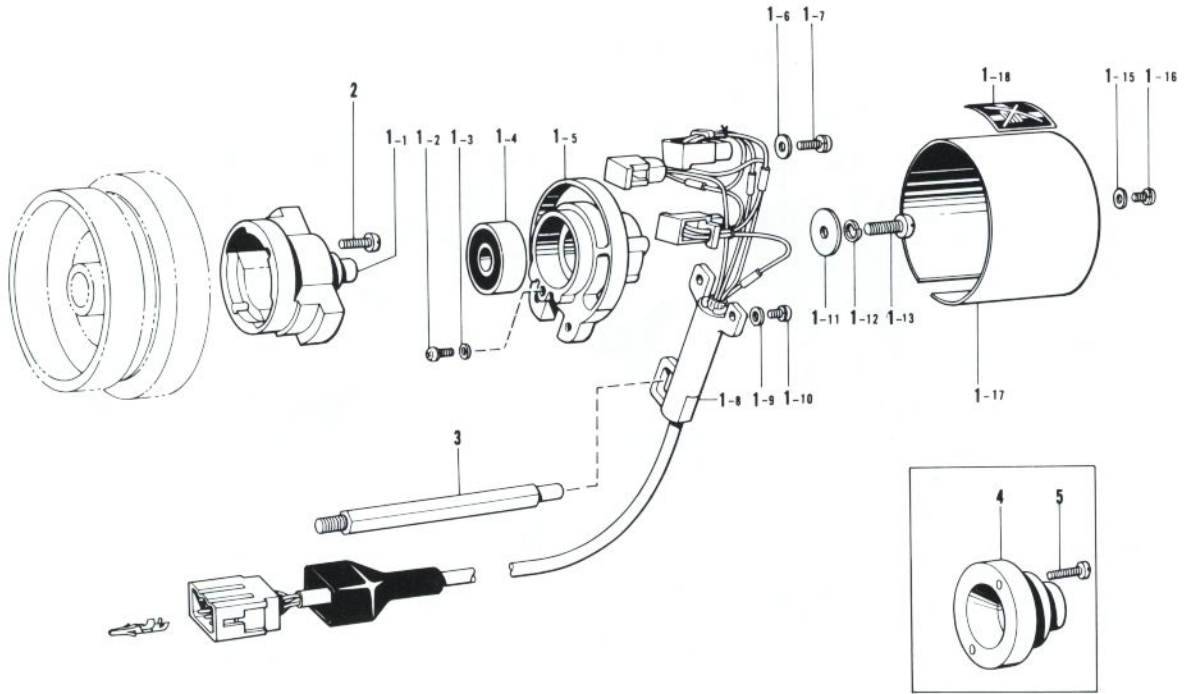

Ref. No.	Name of Parts	Q'ty	Parts No.	Assembly No.	Ref. No.	Name of Parts	Q'ty	Parts No.	Assembly No.
M-1- 1	Magnet Stud	1		M-1 Synchronizer Assembly #6-1 220067-0-01	M-1-12	Washer	1	028060-2-43	M-1 Synchronizer Assembly #6-1 220067-0-01
M-1- 2	Screw	1	215083-0-01		M-1-13	Screw	1	216880-0-01	
M-1- 3	Washer	1	025030-3-35		M-1-15	Washer	2	025040-3-35	
M-1- 4	Ball Bearing	1			M-1-16	Screw	2	215080-0-01	
M-1- 5	Synchronizer Holder	1			M-1-17	Synchronizer Cover	1		
M-1- 6	Washer	3	025040-3-35		M-1-18	Label	1		
M-1- 7	Screw	3	217093-0-01		M-2	Screw		009711-4-12	
M-1- 8	Hole I.C With Cord	1			M-3	Synchronizer Holder Stud	1	148615-0-01	
M-1- 9	Washer	2	025040-1-35		M-4	Slip Ring Support	1	148825-0-01	
M-1-10	Screw	2	215080-0-01		M-5	Screw	2	009711-4-12	
M-1-11	Washer	1	025060-3-35						



# N. Thread Trimmer and Tension Release Mechanism -500 Specification

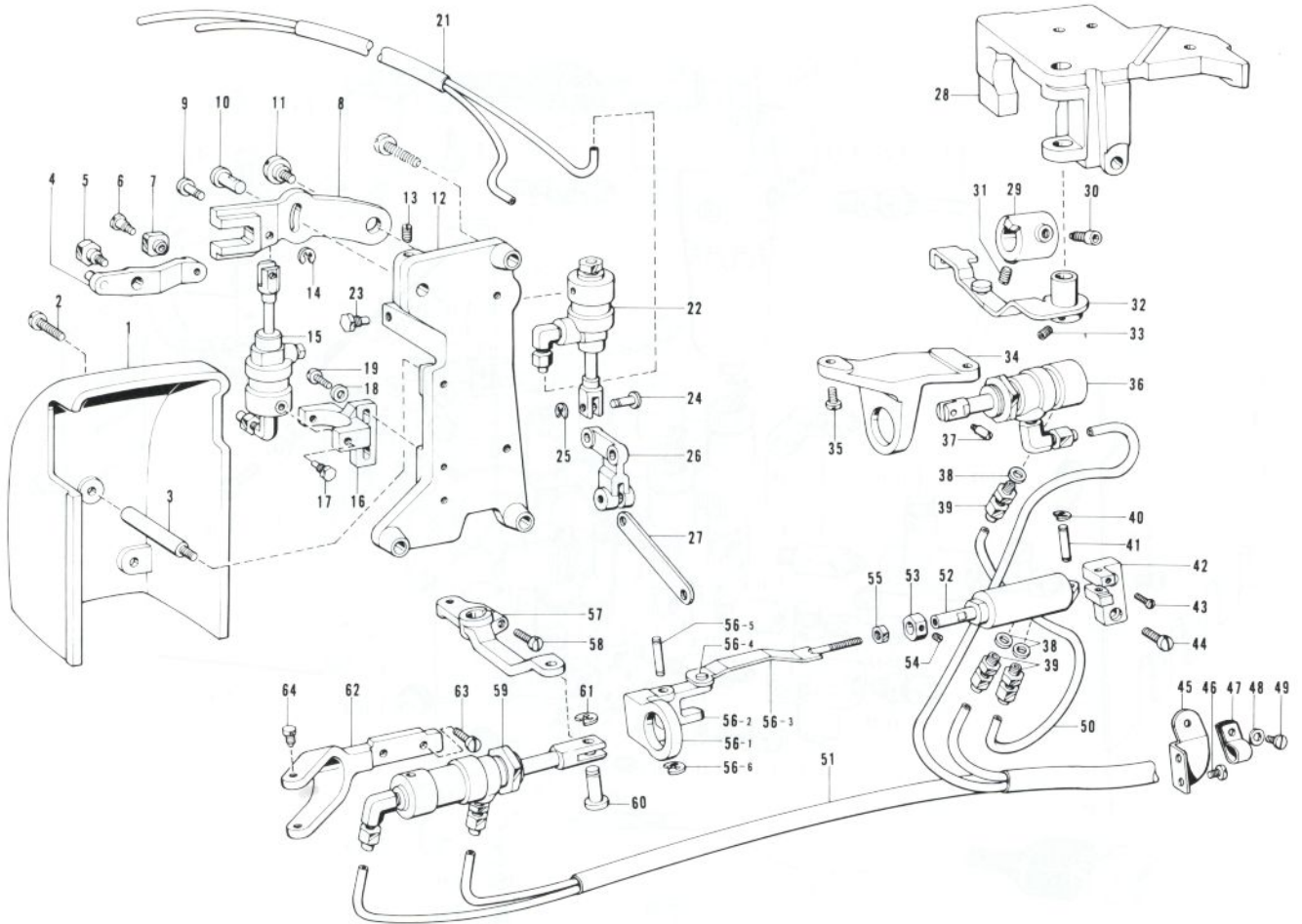

Ref. No.	Name of Parts	Q'ty	Parts No.	Assembly No.	Ref. No.	Name of Parts	Q'ty	Parts No.	Assembly No.
N- 1	Cylinder Cover	1	149035-0-01		N-36	Tension Release Cylinder	1	149043-0-01	
N- 2	Screw	2	009711-2-12		N-37	Plunger Pin	1	148546-0-01	
N- 3	Cylinder Cover Stud	2	149034-0-01		N-38	Packing	3	146699-0-00	
N- 4	Lever Assembly	1	149027-0-01		N-39	Male Connector Assembly	3	149241-0-01	
N- 5	Stud Screw	1	149991-0-01		N-40	Stop Ring	1	048030-3-42	
N- 6	Screw	1	141494-0-01		N-41	Stud	1	149056-0-01	
N- 7	Slide Block Assembly	1	149025-0-01		N-42	Cylinder Supporter	1	149055-0-01	
N- 8	Presser Foot Lifter Lever	1	149024-0-01		N-43	Screw	1	009660-7-12	
N- 9	Pin	1	146153-0-01		N-44	Screw	2	105173-0-04	
N-10	Pin	1	118713-0-01		N-45	Tube Holder	1	149286-0-01	
N-11	Screw	1	141439-0-01		N-46	Screw	2	009670-8-12	
N-12	Cylinder Base	1	149030-0-01		N-47	Nylon Clamp	1	149287-0-00	
N-13	Screw	1	013710-7-12		N-48	Washer	1	105161-0-02	
N-14	Stop Ring	1	048040-3-42		N-49	Screw	1	009670-8-12	
N-15	Presser Foot Lifter Cylinder	1	149019-0-01		N-50	Air Tube	1	149283-0-00	
N-16	Cylinder Supporter	1	149023-0-01		N-51	Air Tube Assembly	1	149284-0-01	
N-17	Screw	2	140620-0-01		N-52	Transfer Cylinder	1	149052-0-01	
N-18	Washer	2	025710-2-32		N-53	Transfer Cylinder Nut	1	149281-0-01	
N-19	Screw	1	009711-6-12		N-54	Screw	1	117666-0-01	
N-21	Air Tube Assembly	1	149285-0-01		N-55	Nut	1	021670-1-02	
N-22	Reverse Cylinder	1	149031-0-01		N-56-1	Valve Lever Supporter	1		N-56 Valve Lever Assembly 149058-0-01
N-23	Screw	2	140620-0-01		N-56-2	Valve Lever	1		
N-24	Pin	1	146153-0-01		N-56-3	Valve Connecting Rod	1		
N-25	Stop Ring	1	048040-3-42		N-56-4	Pin	1		
N-26	Reverse Link Lever	1	149033-0-01		N-56-5	Stud	1	149056-0-01	
N-27	Reverse Link	1	149063-0-01		N-56-6	Stop Ring	2	048030-3-42	
N-28	Movable Knife Base Bracket	1	149036-0-01		N-57	Thread Trimming Lever	1	149042-0-01	
N-29	Tension Release Cam	1	149061-0-01		N-58	Screw	1	009711-4-12	
N-30	Screw	1	148574-0-01		N-59	Thread Trimming Cylinder	1	149037-0-01	
N-31	Screw	1	014770-6-22		N-60	Pin	1	146153-0-01	
N-32	Tension Release Lever	1	149050-0-01		N-61	Stop Ring	1	048040-3-42	
N-33	Screw	2	014770-6-22		N-62	Cylinder Supporter	1	149040-0-01	
N-34	Tension Release Cylinder Base	1	149049-0-01		N-63	Screw	2	009711-6-12	
N-35	Screw	2	009711-0-12		N-64	Screw	2	140620-0-01	

# Q. Control Box Mechanism -500 Specification

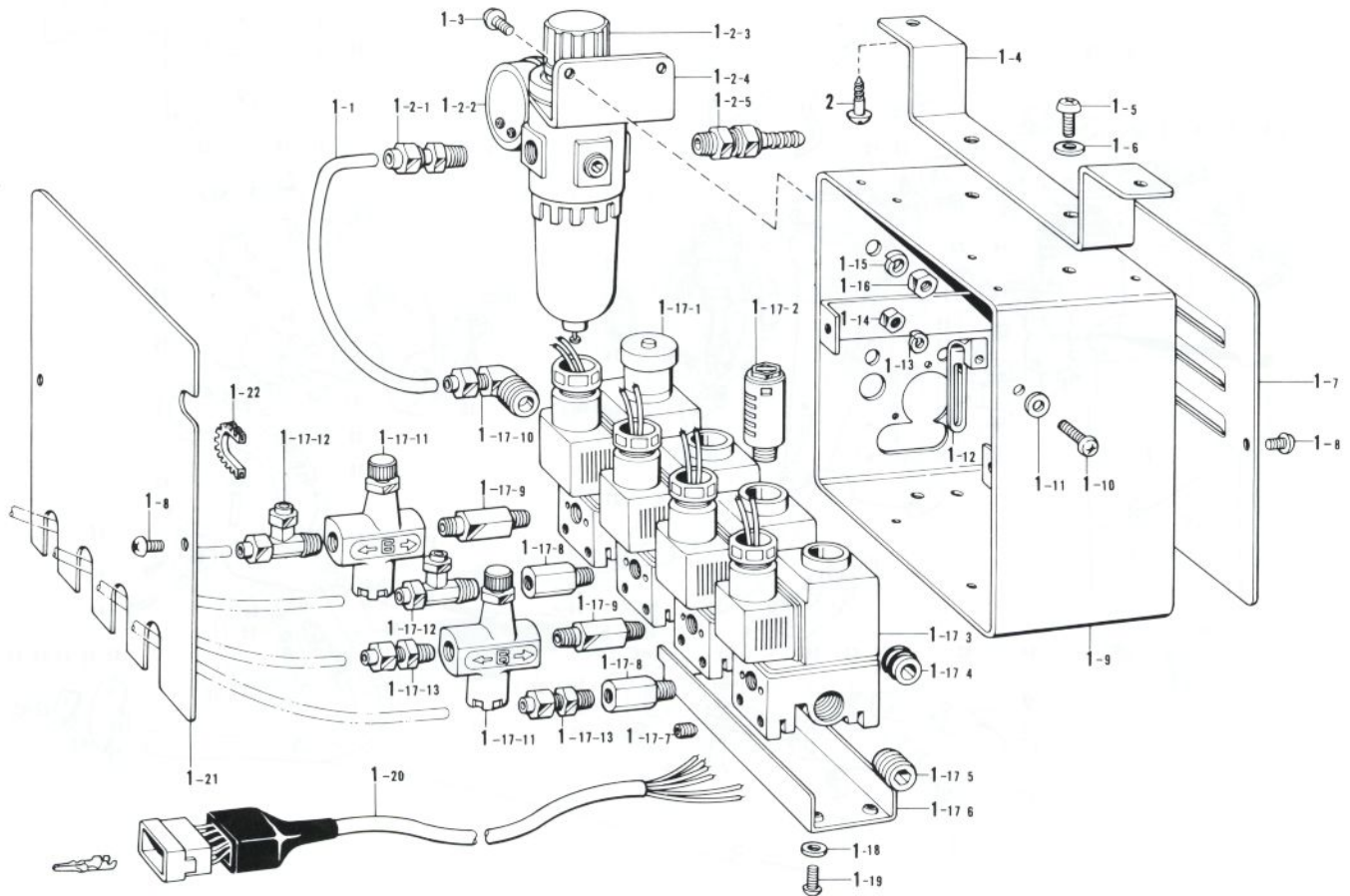

Ref. No.	Name of Parts	Q'ty	Parts No.	Assembly No.	Ref. No.	Name of Parts	Q'ty	Parts No.	Assembly No.
Q-1- 1	Air Tube	1	140540-0-00	Q-1-2 Air Unit Assembly 143959-1-04	Q-1-17- 1	Solenoid Valve	1	149156-0-01	Q-1-17 Solenoid Valve Assembly 149155-0-01
Q-1- 2-1	1/4" Connector Assembly	1	142349-0-00		Q-1-17- 2	Silencer	3	140682-0-01	
Q-1- 2-2	Presser Gauge	1			Q-1-17- 3	Solenoid Valve	3	145827-0-01	
Q-1- 2-3	Valve	1	143960-1-01		Q-1-17- 4	Bushing with "O" Ring	3	140680-0-00	
Q-1- 2-4	Air Unit Holder Plate	1			Q-1-17- 5	1/4" Cap	1	140542-0-01	
Q-1- 2-5	Air Tube Connector	1	140678-0-00	Q-1-17- 6	Solenoid Valve Base	1	149157-0-01		
Q-1- 3	Screw	2	002501-0-64	Q-1-17- 7	Screw	16	016500-8-22	Q-1 Valve Box Assembly 149153-0-01	
Q-1- 4	Air Control Box Base	1	148968-0-01	Q-1-17- 8	Valve Connector	2	140539-0-00		
Q-1- 5	Screw	2	002501-0-64	Q-1-17- 9	Speed Control Connector	2	142037-0-00		
Q-1- 6	Washer	2	025050-1-34	Q-1-17-10	1/4" Elbow	1	140538-0-00		
Q-1- 7	Face Cover	1		Q-1-17-11	Speed Connector	2	142038-0-01		
Q-1- 8	Screw	4	008400-5-64	Q-1-17-12	Air Tube Connector	2	140544-0-00		
Q-1- 9	Valve Box	1		Q-1-17-13	1/8" Connector	2	140543-0-00		
Q-1-10	Screw	1	002301-0-03	Q-1-18	Washer	4	025040-2-33		
Q-1-11	Washer	1	025030-1-33	Q-1-19	Screw	4	002400-8-03		
Q-1-12	Cord Holder	1	144910-0-01	Q-1-20	Valve Cord Assembly	1	149290-0-01		
Q-1-13	Washer	1	028030-2-43	Q-1-21	Rear Cover	1			
Q-1-14	Nut	1	021300-1-03	Q-1-22	Nylon Bushing	1	146171-0-00		
Q-1-15	Washer	2	028050-2-43	Q-2	Screw	2	100666-0-02		
Q-1-16	Nut	3	021500-1-63						



## R. Presser Foot Lifter Cord Mechanism -500 Specification

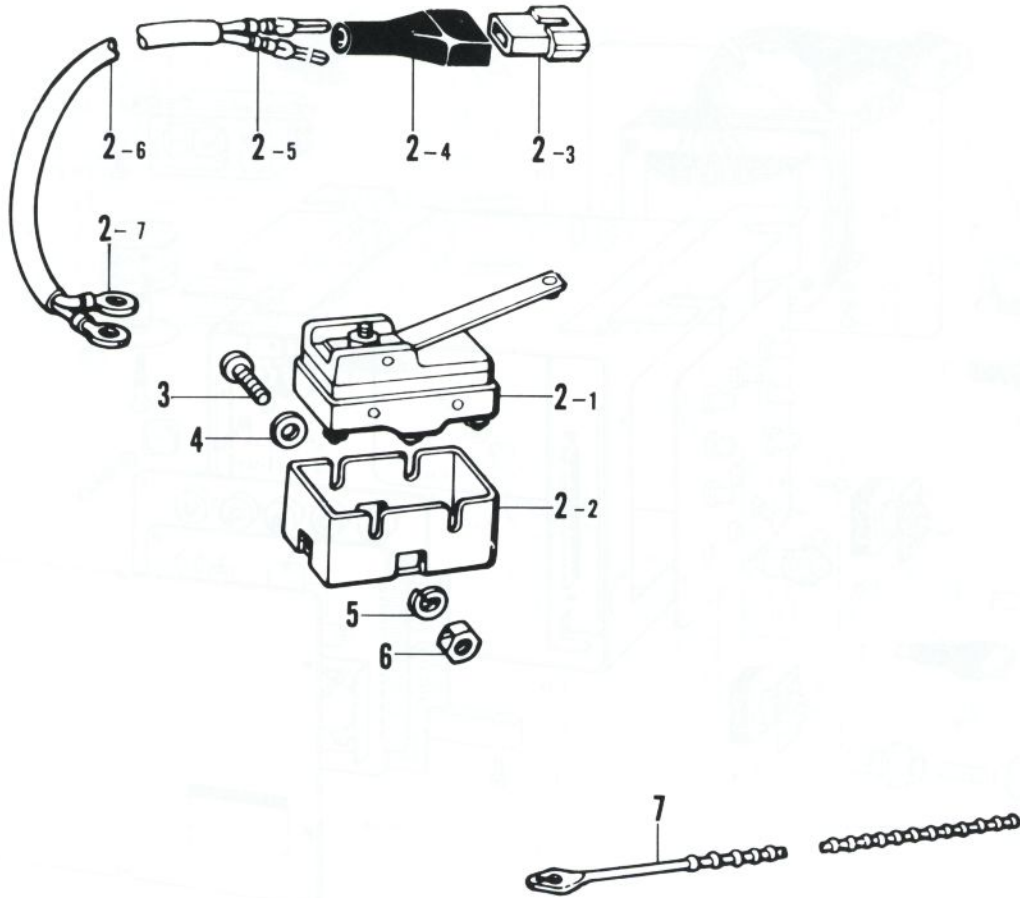

Ref. No.	Name of Parts	Q'ty	Parts No.	Assembly No.	Ref. No.	Name of Parts	Q'ty	Parts No.	Assembly No.
R-2-1	Micro Switch Assembly	1	140948-0-01	R-2 Presser Foot Lifter Cord Assembly 146160-0-01	R-2-7	Terminal	2	140693-0-00	R-2 146160-0-01
R-2-2	Cover	1	140950-0-00		R-3	Screw	2	002303-0-06	
R-2-3	Nylon Connector	1	143488-0-01		R-4	Washer	2	025030-2-33	
R-2-4	Connector Cap	1	143489-0-01		R-5	Washer	2	028030-2-43	
R-2-5	Terminal Pin	2	143549-0-00		R-6	Nut	2	021300-1-03	
R-2-6	Presser Foot Lifter Cord	1			R-7	Bead Band	1	144189-0-01	

# S. Control Box Mechanism -400 · -500 Specification

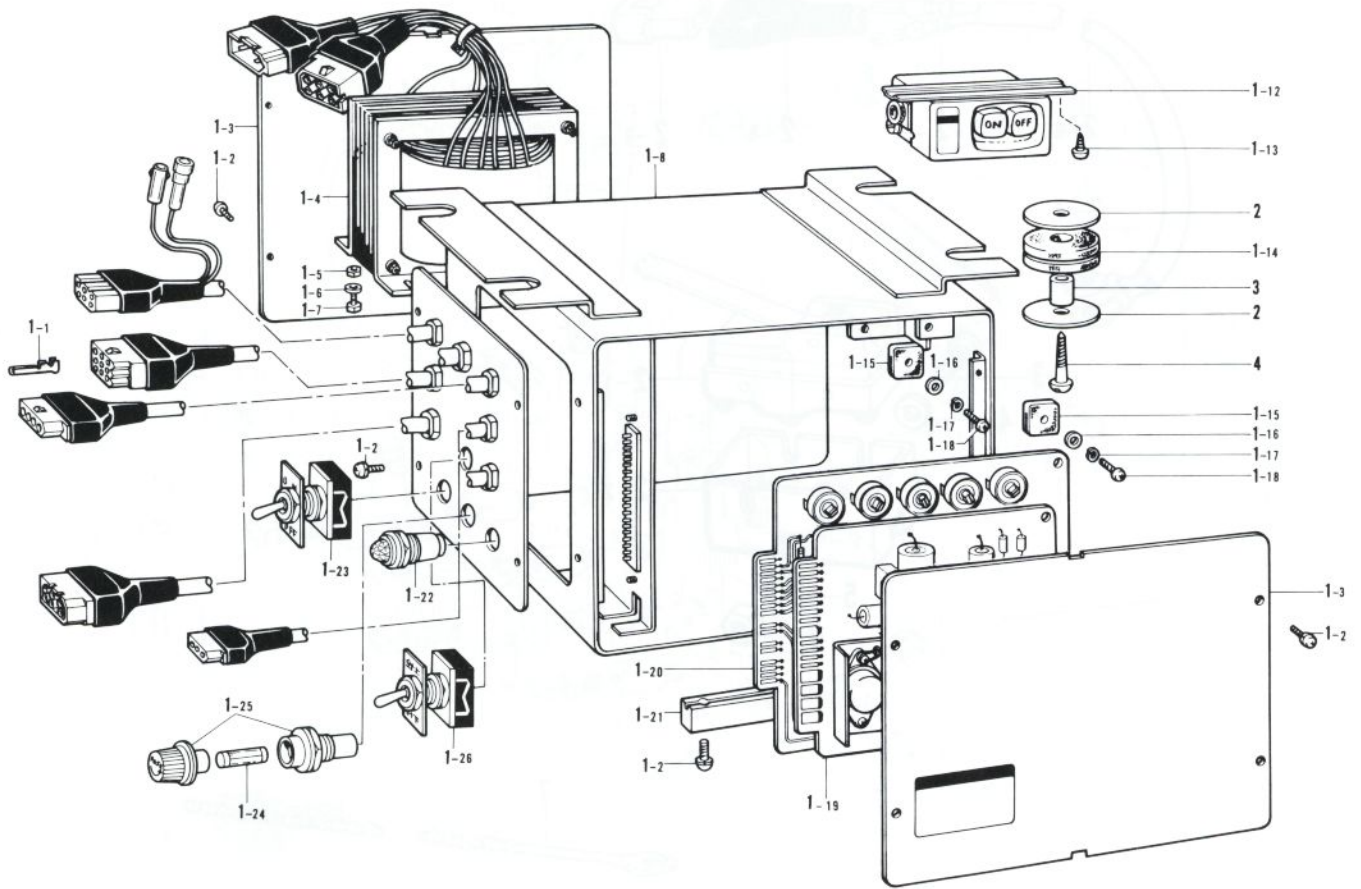

Ref. No.	Name of Parts	Q'ty	Parts No.	Assembly No.	Ref. No.	Name of Parts	Q'ty	Parts No.	Assembly No.
S-1- 1	Terminal Pin	22	216373-0-01	S-1 Control Box Assembly	S-1-17	Washer	1	028030-2-43	S-1 Control Box Assembly
S-1- 2	Screw	8	215080-0-01		S-1-18	Screw	2	002300-8-05	
S-1- 3	Control Box Front Cover Plate	2	216342-0-01		S-1-19	Printed Circuit Board	1	219212-0-00	
S-1- 4	Transformer	1			S-1-20	Printed Circuit Board	1	219211-0-00	
S-1- 5	Nut	4	218823-0-01		S-1-21	Mounting Rail	2	218821-0-01	
S-1- 6	Washer	4	025040-2-35		S-1-22	Pilot Lamp	1	216364-0-00	
S-1- 7	Screw	4	216870-0-01		S-1-23	Pilot Lamp Switch	1	216905-0-01	
S-1- 8	Control Box	1			S-1-24	8A Fuse	1	219225-0-00	
S-1-12	3p Push Button Switch	1	213794-0-01		S-1-25	Fuse Holder	1	215387-0-01	
S-1-13	Screw	2	031451-6-03		S-1-26	Switch	1	219214-0-01	
S-1-14	Cushion Rubber	4	216345-0-00		S-2	Washer	8	214344-0-01	
S-1-15	Insulator Rubber	1	216351-0-01		S-3	Collar	4	216346-0-01	
S-1-16	Washer	2	025030-3-35		S-4	Screw	4	031624-0-05	



# T. Motor (Part 1) -400 · -500 Specification

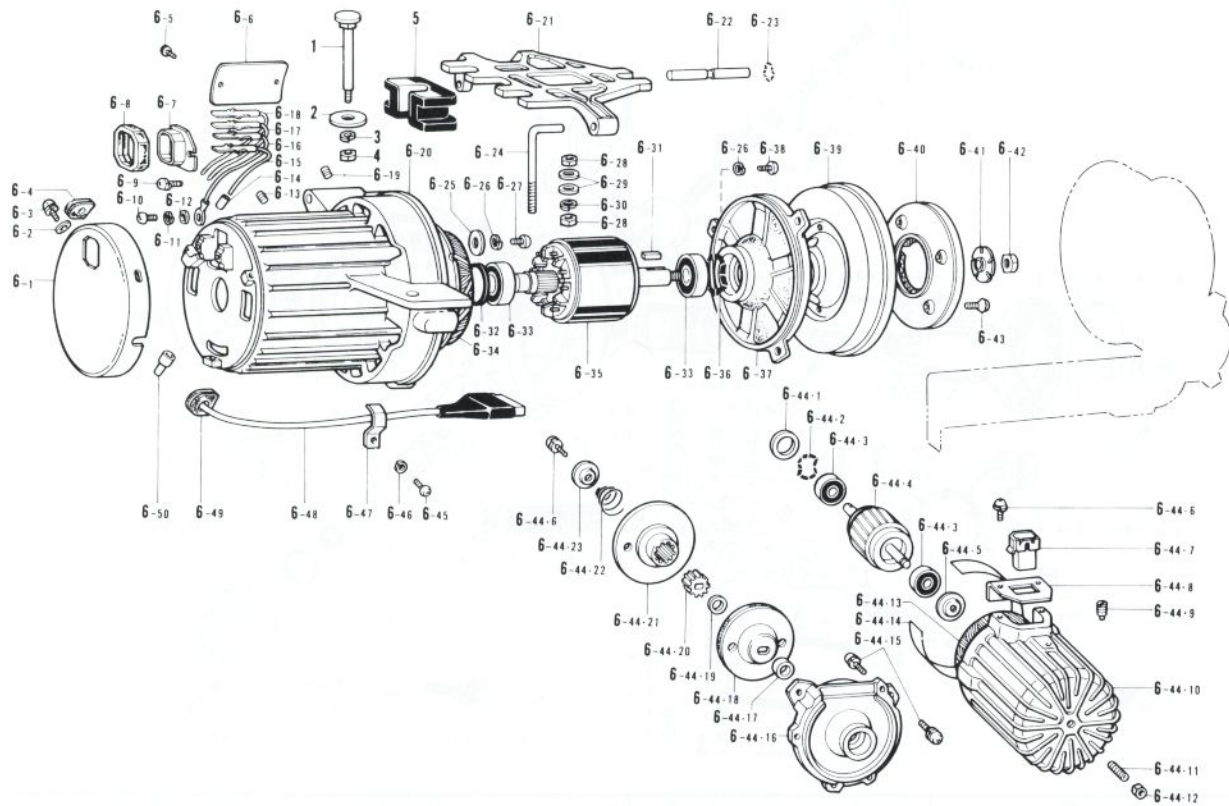

Ref. No.	Name of Parts	Q'ty	Parts No.	Assembly No.	Ref. No.	Name of Parts	Q'ty	Parts No.	Assembly No.
T-1	Bolt	3	210973-0-01		T-6-35	Rotor	1	213802-0-01	
T-2	Washer	3	213650-0-01		T-6-36	Washer	1	206156-0-01	
T-3	Washer	3	028080-2-43		T-6-37	Bracket	1	218871-0-01	
T-4	Nut	3	021080-1-06		T-6-38	Screw	3	002501-6-05	T-6 Motor Assembly
T-5	Vibration Absorbing Rubber	3	213646-0-01		T-6-39	Fly Wheel	1	218872-0-01	
T-6- 1	Frame Cover	1	218863-0-01		T-6-40	Clutch Lining #4	1	218873-0-00	
T-6- 2	Washer	3	025050-2-35		T-6-41	Washer	1	210941-0-02	
T-6- 3	Screw	3	211528-0-01		T-6-42	Nut	1	210942-0-02	
T-6- 4	Rubber Pad #72	1	218865-0-01		T-6-43	Screw	4	214897-0-01	
T-6- 5	Pin	2	200084-0-02		T-6-44- 1	Washer	2	218913-0-01	
T-6- 6	Model Plate	1			T-6-44- 2	Washer	3	218870-0-01	
T-6- 7	7P Socket	1	213748-0-01		T-6-44- 3	Bearing 608VV	2	072060-8-60	
T-6- 8	7P Socket Cover	1	218862-0-01		T-6-44- 4	Roter	1	218907-0-01	
T-6- 9	Screw	2	008400-8-06		T-6-44- 5	Roter Push Plate	1	218910-0-00	
T-6-10	Screw	1	002401-0-63		T-6-44- 6	Screw	3	215080-0-01	
T-6-11	Washer	1	028040-2-43		T-6-44- 7	3P Plug	1	216299-0-01	
T-6-12	Nut	1	025040-1-73		T-6-44- 8	Plug Set Plate	1	216300-0-01	
T-6-13	Screw	1	013080-8-13		T-6-44- 9	Screw	1	216286-0-01	
T-6-14	Vinyl Cap for Lead Wire	2	218951-0-01		T-6-44-10	Sed Motor Fram #55	1	218911-0-01	
T-6-15	Lead Wire (White)	2	218861-0-01	T-6 Motor Assembly	T-6-44-11	Screw	1	012061-8-22	T-6-44 Sub Motor Assembly 218906-0-01
T-6-16	Lead Wire for Earth	1	213792-0-01		T-6-44-12	Nut	1	021060-3-05	
T-6-17	Lead Wire (Read)	1	218861-0-02		T-6-44-13	Stator	1	218914-0-00	
T-6-18	Lead Wire (Black)	1	218861-0-03		T-6-44-14	Insulator Paper	2	216284-0-00	
T-6-19	Screw	1	011060-6-13		T-6-44-15	Screw	3	211528-0-01	
T-6-20	Frame #54	1	218831-0-01		T-6-44-16	Bracket	1	218912-0-00	
T-6-21	Base	1	218874-0-01		T-6-44-17	Collar	1	218922-0-01	
T-6-22	Pin	1	218875-0-01		T-6-44-18	Clutch Plate	1	218916-0-01	
T-6-23	Washer	1	213765-0-01		T-6-44-19	Washer	1	218921-0-01	
T-6-24	Bolt Adjusting Rod	1	210965-0-01		T-6-44-20	Selation	1	217280-0-01	
T-6-25	Washer	3	213752-0-01		T-6-44-21	Round Plate	1	218918-0-01	
T-6-26	Spring Washer	6	028050-2-43		T-6-44-22	Spring	1	218919-0-01	
T-6-27	Screw	3	218905-0-01		T-6-44-23	Washer	1	218920-0-00	
T-6-28	Nut	2	021100-2-06		T-6-45	Screw	1	002500-8-06	
T-6-29	Washer	2	025100-2-36		T-6-46	Spring Washer	1	028050-2-43	
T-6-30	Washer	1	028100-2-43		T-6-47	Cord Holder	1	218866-0-01	
T-6-31	Key	1	210940-0-00		T-6-48	Plug for Sub Motor	1	218867-0-01	
T-6-32	Rubber Washer 708 x 35 x 40RU	1	210938-0-01		T-6-49	Rubber Pad #71	1	218864-0-01	
T-6-33	Bearing 6203VV	2	072620-3-60		T-6-50	Crimp Connector	3	217169-0-00	
T-6-34	Stator	1	218851-0-01						

From the library of: Diamond Needle Corp

# T. Motor (Part 2) -400 · -500 Specification

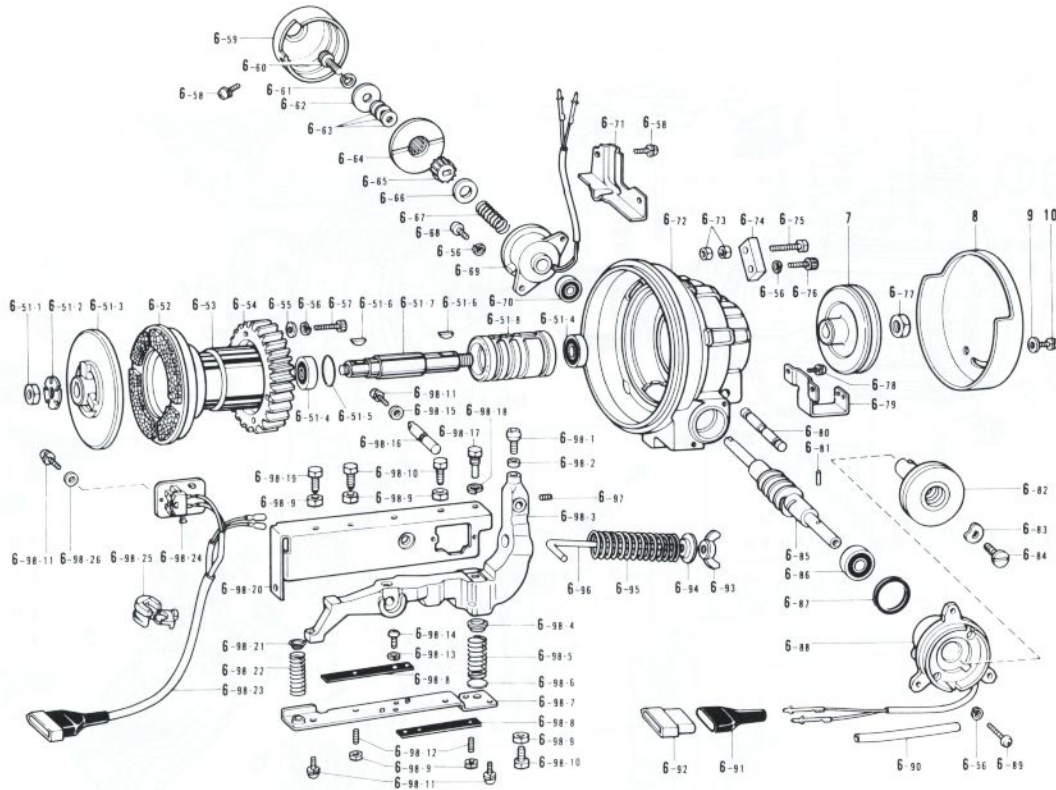

Ref. No.	Name of Parts	Q'ty	Parts No.	Assembly No.	Ref. No.	Name of Parts	Q'ty	Parts No.	Assembly No.
T-6-51-1	Nut	1	210942-0-02	T-6-51 Clutch Plate #8 Assembly 218877-0-01	T-6-86	Bearing 6201VV	1	072620-1-61	T-6 Motor Assembly
T-6-51-2	Washer	1	210941-0-02		T-6-87	Washer	1	216277-0-01	
T-6-51-3	Clutch Plate #6	1	213750-0-00		T-6-88	Clutch Solenoid	1	218903-0-01	
T-6-51-4	Bearing 620VV	2	072620-2-60		T-6-89	Screw	2	002503-5-05	
T-6-51-5	Washer	1	210948-0-01		T-6-90	Vinyl Tube	1	216837-0-01	
T-6-51-6	Key	2	210421-0-00		T-6-91	Plug Cover	1	216248-0-01	
T-6-51-7	Clutch Shaft	1	218878-0-00		T-6-92	4P Plug	1	216247-0-01	
T-6-51-8	Clutch Shaft Supporter	1	218879-0-01		T-6-93	Nut	1	206337-0-02	
T-6-52	Brake Lining	1	218882-0-00		T-6-94	Spring Cap	1	213760-0-01	
T-6-53	Supporter for Clutch Shaft Supporter	1	290439-0-00		T-6-95	Spring	1	218929-0-01	
T-6-54	Gear 1/21	1	216219-0-00	T-6-96	Pedal Pressure Adjusting Screw	1	218928-0-01		
T-6-55	Washer	4	025050-1-35	T-6-97	Screw	1	014061-0-22		
T-6-56	Washer	9	028050-2-43	T-6-98-1	Ball Screw	1	216225-0-01	T-6-98 Clutch Lever #8 Assembly 218923-0-01	
T-6-57	Screw	4	018502-5-22	T-6-98-2	Nut	1	218921-0-01		
T-6-58	Screw	4	215080-0-01	T-6-98-3	Clutch Lever	1	218924-0-01		
T-6-59	Brake Cover	1	218902-0-01	T-6-98-4	Spring Cap	1	216233-0-01		
T-6-60	Bolt	1	018401-4-22	T-6-98-5	Spring	1	218945-0-01		
T-6-61	Spring Washer	1	028040-2-43	T-6-98-6	Washer	1	216235-0-00		
T-6-62	Washer	1	218896-0-00	T-6-98-7	Clutch Lever Bottom Plate	1	218946-0-01		
T-6-63	Spacer	4	218860-0-01	T-6-98-8	Switch Presser Plate	2	216241-0-01		
T-6-64	Brake Disc	1	218895-0-01	T-6-98-9	Nut	6	021060-3-05		
T-6-65	Selation	1	217280-0-01	T-6-98-10	Bolt	3	213913-0-01		
T-6-66	Washer	1	218894-0-01	T-6-98-11	Screw	8	215080-0-01		
T-6-67	Spring	1	218893-0-01	T-6-98-12	Screw	2	012061-2-22		
T-6-68	Screw	2	002501-6-05	T-6-98-13	Spring Washer	2	028040-2-43		
T-6-69	Brake Solenoid	1	218915-0-01	T-6-98-14	Screw	2	002400-6-05		
T-6-70	Bearing 608VV	1	072060-8-60	T-6-98-15	Washer	1	025040-3-35		
T-6-71	Cord Holder	1	218930-0-01	T-6-98-16	Pin	1	218926-0-01		
T-6-72	Bracket	1	218876-0-01	T-6-98-17	Bolt	1	216232-0-01		
T-6-73	Nut	2	021060-3-05	T-6-98-18	Washer	1	028060-2-43		
T-6-74	Space Adjusting Plate	1	218881-0-01	T-6-98-19	Bolt	1	214002-0-01		
T-6-75	Bolt	1	219405-0-01	T-6-98-20	Clutch Lever Cover	1	218925-0-01		
T-6-76	Bolt	1	018502-2-23	T-6-98-21	Spring Cap	1	218927-0-01		
T-6-77	Nut	1	210240-0-01	T-6-98-22	Spring	1	216230-0-01		
T-6-78	Screw	2	211528-0-01	T-6-98-23	Micro Key Cord	1	218947-0-01		
T-6-79	Belt Cover Set Plate	1	216380-0-01	T-6-98-24	Micro Switch	2	216236-0-01		
T-6-80	Pin	1	213757-0-02	T-6-98-25	Bushing	1	212544-0-01		
T-6-81	Spring Pin	1	218952-0-01	T-6-98-26	Washer	4	025040-1-35		
T-6-82	Clutch Plate #2	1	218885-0-01	T-7	Pulley	1			
T-6-83	Washer	1	218891-0-01	T-8	Belt Cover	1	215491-0-01		
T-6-84	Screw	1	218892-0-01	T-9	Washer	2	025050-3-35		
T-6-85	Worm 1/21	1	218884-0-00	T-10	Screw	2	211528-0-01		



## Z. Accessories

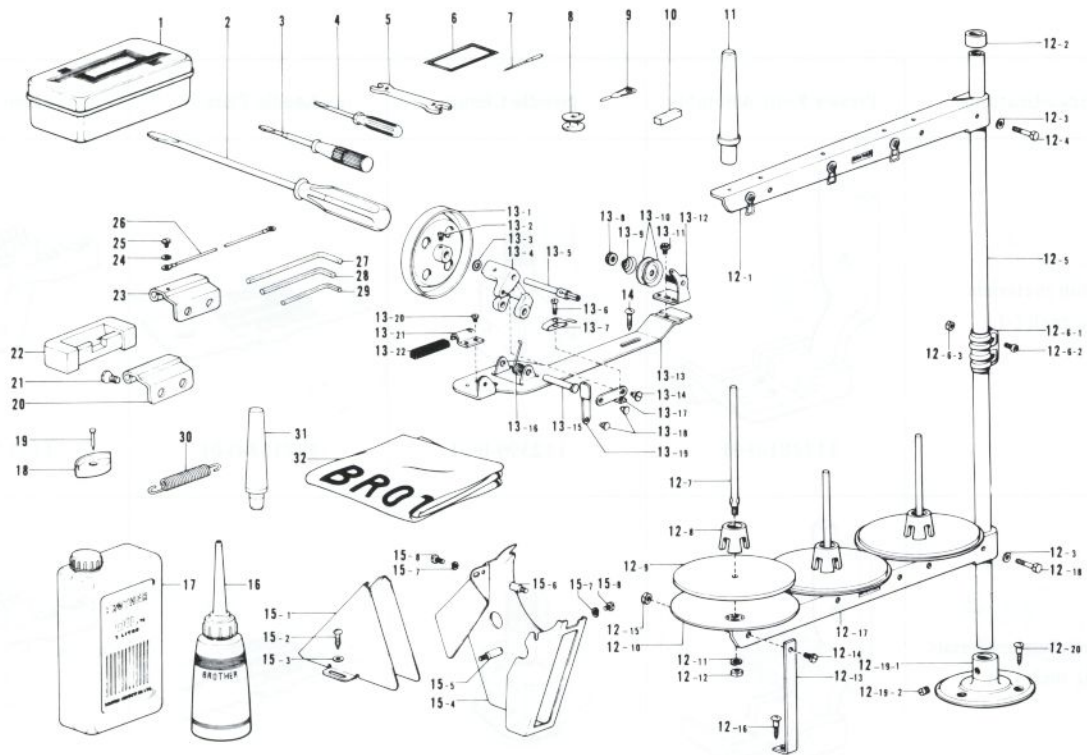

Ref. No.	Name of Parts	Q'ty	Parts No.	Assembly No.	Ref. No.	Name of Parts	Q'ty	Parts No.	Assembly No.
Z- 1	Accessory Box		110436-0-01		Z-13- 8	Tension Control Nut			
Z- 2	Screw Driver		101572-1-01		Z-13- 9	Tension Spring		100401-0-01	
Z- 3	Screw Driver		118837-0-01		Z-13-10	Tension Disc		145446-0-01	
Z- 4	Screw Driver		142443-0-01		Z-13-11	Screw			
Z- 5	Spanner 8 x 9		100887-0-01		Z-13-12	Bobbin Winder Guide Assembly			
Z- 6	Needle Bag				Z-13-13	Bobbin Winder Wheel Bracket			
Z- 7	Needle DP x 5				Z-13-14	Screw		100659-0-01	Z-13 Bobbin Winder Assembly 117963-0-01
Z- 8	Bobbin				Z-13-15	Pin			
Z- 9	Threader		103896-0-02		Z-13-16	Spring		117969-0-01	
Z-10	Felt		114941-0-01		Z-13-17	Bobbin Presser Arm			
Z-11	Head Rest		100477-0-01		Z-13-18	Pin		100661-0-01	
Z-12- 1	Thread Hanger Assembly		150193-0-01		Z-13-19	Bobbin Presser Bracket			
Z-12- 2	Column Cap			Z-12 Cotton Stand Assembly 150151-0-01	Z-13-20	Screw		009679-3-12	
Z-12- 3	Washer		025050-2-33		Z-13-21	Bobbin Winder Wheel Stopper Holder			
Z-12- 4	Bolt		017502-8-03		Z-13-22	Bobbin Winder Wheel Stopper		100662-0-01	
Z-12- 5	Column Pipe		150172-0-01		Z-14	Screw		100666-0-02	
Z-12- 6-1	Joint			Z-12-6 Joint for Cotton Stand 150106-0-01	Z-15- 1	Belt Cover (D)			Z-15 Belt Cover Complete D 147908-0-01
Z-12- 6-2	Screw		150202-0-01		Z-15- 2	Screw		100666-0-02	
Z-12- 6-3	Nut		021500-1-03		Z-15- 3	Washer		025750-1-32	
Z-12- 7	Spool Shaft (B)		150179-0-01		Z-15- 4	Belt Cover UD			
Z-12- 8	Spool Cushion		147060-0-01		Z-15- 5	Belt Cover Stud (B)		147856-0-02	
Z-12- 9	Spool Mat		150182-0-00		Z-15- 6	Belt Cover Stud		147858-0-01	
Z-12-10	Spool Disc		150180-0-00		Z-15- 7	Washer		028680-2-42	
Z-12-11	Washer		028050-2-43		Z-15- 8	Screw		009680-8-12	
Z-12-12	Nut		021500-1-03	Z-12 Cotton Stand Assembly 150151-0-01	Z-16	Oiler		114483-0-01	
Z-12-13	Spool Holder Supporter		150188-0-01		Z-17	Oil Tank		145277-1-03	
Z-12-14	Screw		007501-0-03		Z-18	Head Cushion		148890-1-01	
Z-12-15	Nut		021500-1-03		Z-19	Nail		109714-0-00	
Z-12-16	Screw		031452-2-03		Z-20	Head Hinge		148882-0-01	
Z-12-17	Spool Holder Assembly		150175-0-01		Z-21	Screw		112569-0-01	
Z-12-18	Bolt		017502-8-03		Z-22	Rubber Hinge		143910-0-01	
Z-12-19-1	Cotton Stand Base		150189-0-01	Z-12-19 Bracket Assembly 150139-0-01	Z-23	Head Hinge		150577-0-01	
Z-12-19-2	Screw		150181-0-01		Z-24	Washer		025680-2-34	
Z-12-20	Screw		031452-2-03		Z-25	Screw		009680-6-13	
Z-13- 1	Bobbin Winder Wheel Assembly				Z-26	Earth Wire		145946-0-01	
Z-13- 2	Screw		100366-0-02		Z-27	Spanner		149570-0-01	
Z-13- 3	Washer			Z-13 Bobbin Winder Assembly 117963-0-01	Z-28	Spanner 3		142721-0-01	
Z-13- 4	Bobbin Winder Wheel Shaft Supporter				Z-29	Spanner (2 mm)		142002-0-01	
Z-13- 5	Bobbin Winder Shaft		117970-0-01		Z-30	Spring			
Z-13- 6	Screw		100657-0-01		Z-31	Head Rest		149010-0-00	
Z-13- 7	Bobbin Presser				Z-32	Head Cover		144222-0-01	

\*The details of included accessories are subject to change.

\*Les détails des accessoires inclus sont sujets à des changements.

\*Änderungen in der Aufstellung der mitgelieferten Zubehöre sind vorbehalten.

\*Los detalles de los accesorios incluidos pueden variar.

# Gauge Parts for Standard (-1 · -3 · -5)

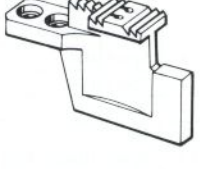







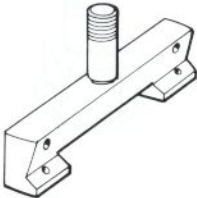
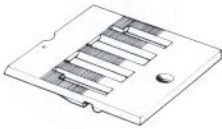
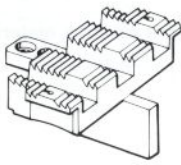

Specifications	Presser Foot Assembly	Needle Clamp	Needle Plate	Feed Dog
For thin materials $\frac{3}{16}$ inch (-1)	 117281-0-01	 112599-0-01	 117158-0-01	 117134-0-01
For medium materials $\frac{3}{16}$ inch (-3)	 112638-0-01	 112599-0-01	 112603-0-01	 112659-0-01
For medium materials $\frac{1}{4}$ inch (-3)	 112642-0-01	 112600-0-01	 112604-0-01	 112660-0-01
For medium materials $\frac{1}{8}$ inch (-3)	 114948-0-01	 114947-0-01	 114950-0-01	 114951-0-01
For medium materials $\frac{5}{16}$ inch (-3)	 112645-0-01	 112601-0-01	 112605-0-01	 112661-0-01

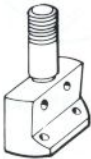
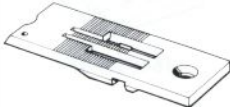
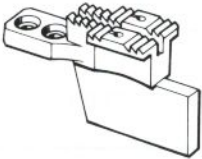

# Gauge Parts for Standard (-1 · -3 · -5)

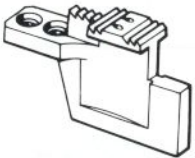

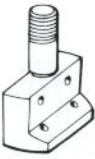

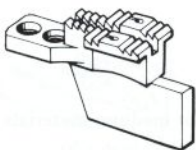

Specifications	Presser Foot Assembly	Needle Clamp	Needle Plate	Feed Dog
For medium materials 5/32 inch (-3)	 116502-0-01	 116489-0-01	 116503-0-01	 116509-0-01
For medium materials 3/8 inch (-3)	 116498-0-01	 116491-0-01	 116506-1-01	 116510-1-01
For medium materials 1/2 inch (-3)	 116499-0-01	 116490-0-01	 116505-0-01	 116511-0-01
For medium materials 5/8 inch (-3)	 116500-0-01	 116488-0-01	 116507-0-01	 116512-0-01
For medium materials 1 1/4 inch (-3)	 116501-0-01	 116492-0-01	 116504-0-01	 116508-0-01

# Gauge Parts for Standard (-1 · -3 · -5)

Specifications	Presser Foot Assembly	Needle Clamp	Needle Plate	Feed Dog
For medium materials 1½ inch (-3)	 118946-0-01	 118944-0-01	 118945-0-01	 118947-0-01
For thick materials ¼ inch (-5)	 112642-0-01	 112600-0-01	 117367-0-01	 112660-0-01
For thick materials ⅛ inch (-5)	 114948-0-01	 114947-0-01	 117369-0-01	 114951-0-01
For thick materials ⅙ inch (-5)	 112645-0-01	 112601-0-01	 144882-0-01	 112661-0-01

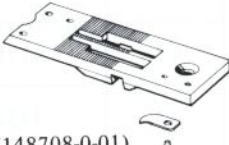
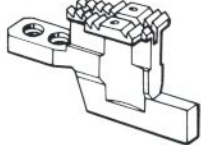
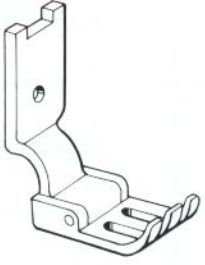

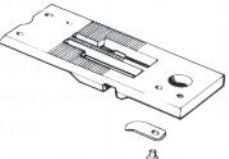
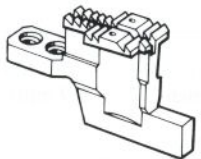
# Gauge Parts for Thread Trimmer (-400 · -500)

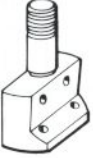
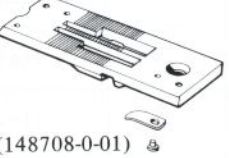
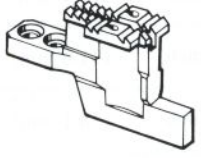
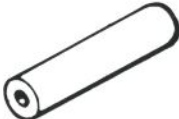
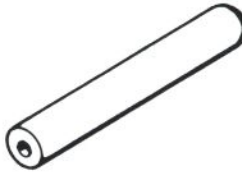
Specifications	Presser Foot Assembly	Needle Clamp	Needle Plate	Feed Dog
For medium materials $\frac{3}{16}$ inch (-403 · -503)	 148687-0-01	 112599-0-01	 (148708-0-01) (148709-0-01) 148718-0-01	 148702-0-01
For medium materials $\frac{1}{4}$ inch (-403 · -503)	 148693-0-01	 112600-0-01	 (148708-0-01) (148709-0-01) 148722-0-01	 148704-0-01
For thick materials $\frac{1}{4}$ inch (-405 · -505)	 148695-0-01	 112600-0-01	 (148708-0-01) (148709-0-01) 148724-0-01	 148705-0-01
Thread Trimmer materials	Thread Wiper Holder $\frac{3}{32}$ " ~ $\frac{1}{2}$ "  148528-0-01		Thread Wiper Holder (L) $\frac{5}{8}$ " ~ 1"  149986-0-01	

## GAUGE PARTS LIST

For Standard (-1 · -3 · -5)

Needle Gauge	Sub-Class	Needle Plate	Feed Dog	Presser Foot Assembly	Needle Clamp
3/16 inch ( 4.8 mm)	-1	117158-0-01	117134-0-01	117281-0-01	112599-0-01
	-3	112603-0-01	112659-0-01	112638-0-01	
	-5	117133-0-01			
1/4 inch ( 6.4 mm)	-1	117368-0-01	117365-0-01	149312-0-01	112600-0-01
	-3	112604-0-01	112660-0-01	112642-0-01	
	-5	117367-0-01			
1/8 inch ( 3.2 mm)	-1	117370-0-01	117366-0-01	149311-0-01	114947-0-01
	-3	114950-0-01	114951-0-01	114948-0-01	
	-5	117369-0-01			
5/16 inch ( 7.9 mm)	-3	112605-0-01	112661-0-01	112645-0-01	112601-0-01
	-5	144882-0-01			
3/8 inch ( 9.5 mm)	-3	116506-1-01	116510-1-01	116498-0-01	116491-0-01
	-5	144881-1-01			
5/32 inch ( 4.0 mm)	-3	116503-0-01	116509-0-01	116502-0-01	116489-0-01
1/2 inch (12.7 mm)	-3	116505-0-01	116511-0-01	116499-0-01	116490-0-01
5/8 inch (15.9 mm)	-3	116507-0-01	116512-0-01	116500-0-01	116488-0-01
1 1/4 inch (31.8 mm)	-3	116504-0-01	116508-0-01	116501-0-01	116492-0-01
1 1/2 inch (38.1 mm)	-3	118945-0-01	118947-0-01	118946-0-01	118944-0-01
1/16 inch (1.59 mm)	-3	142111-0-01	/	/	/
2 1/6 inch (55.0 mm)	-5	147560-0-01	147561-0-01	147562-0-01	147564-0-01
2 inch (50.8 mm)	-3	144951-0-01	144947-0-01	144949-0-01	144948-0-01
Longitudinal 2 (50.8 mm)	-1 · -5	/	142110-0-01	142105-0-01	142109-0-01



## GAUGE PARTS LIST

For Thread Trimmer (-400 · -500)

Needle Gauge	Sub Class	Needle Plate Assembly	Feed Dog	Presser Foot Assembly	Needle Clamp	Connecting Rod Assembly
3/16 inch ( 4.8 mm)	-1 · -3	148718-0-01	148702-0-01	148687-0-01	112599-0-01	148585-0-01
	-5	148720-0-01	148703-0-01	148691-0-01		
		153236-0-01				
1/4 inch ( 6.4 mm)	-1 · -3	148722-0-01	148704-0-01	148693-0-01	112600-0-01	
	-5	148724-0-01	148705-0-01	148695-0-01		
		153238-0-01				
5/16 inch ( 7.9 mm)	-1 · -3	149695-0-01	149692-0-01	149689-0-01	112601-0-01	149697-0-01
	-5	149693-0-01	149691-0-01	149687-0-01		
1/8 inch ( 3.2 mm)	-1 · -3	148710-0-01	148698-0-01	148685-0-01	114947-0-01	148581-0-01
	-5	148712-0-01	148699-0-01	148681-0-01		
		153234-0-01				
3/8 inch ( 9.5 mm)	-1 · -3	149946-0-01	149939-0-01	149942-0-01	158798 116491-0-01	149697-0-01
	-5	<del>149944-0-01</del> 15857-0-01	149938-0-01	149940-0-01		
5/8 inch (15.9 mm)	-1 · -3	149956-0-01	149949-0-01	149952-0-01	116488-0-01	149958-0-01
	-5	149954-0-01	149948-0-01	149950-0-01		
		153240-0-01	149949-0-01	149952-0-01		
3/32 inch ( 2.4 mm)	-1 · -3	148706-0-01	148697-0-01	148679-0-01	148678-0-01	148581-0-01
	-5	153232-0-01				
5/32 inch ( 4.0 mm)	-1 · -3	148714-0-01	148700-0-01	148689-0-01	116489-0-01	
	-5	148716-0-01	148701-0-01	148683-0-01		
1/2 inch (12.7 mm)	-1 · -3	149679-0-01	149676-0-01	149673-0-01	116490-0-01	149685-0-01
	-5	149677-0-01	149675-0-01	149671-0-01		
3/4 inch (19.0 mm)	-5	150526-0-01	150523-0-01	150524-0-01	150522-0-01	150528-0-01
7/8 inch (22.2 mm)	-5	150534-0-01	150531-0-01	150532-0-01	150530-0-01	150536-0-01
1 inch (25.4 mm)	-5	149966-0-01	149960-0-01	149962-0-01	149985-0-01	149970-0-01

# DIFFERENT PARTS LIST

Ref. No.	Name of Parts	Sub Class	-3									
		Gauge	3/16	3/16	1/4	1/8	5/16	5/32	3/8	1/2	5/8	1.1/4
A-15	Upper Tension Control Assembly		144678-0-01									
A-15-9	Tension Spring		118317-0-01									
A-28	Arm Thread Guide, Lower		112715-0-01									
A-29	Screw		108960-0-04									
A-30	Felt		114941-0-01									
A-31	Pipe		112714-0-00									
A-32	Thread Release Shaft		144823-0-01									
A-35	Needle Plate (Assembly)		117158-0-01	112603-0-01	112604-0-01	114950-0-01	112605-0-01	116503-0-01	116506-1-01	116505-0-01	116507-0-01	116504-0-01
A-36	Screw		117160-0-01	100032-0-03								
A-39	Slide Plate, Left		112606-0-01									
A-41	Slide Plate Front Assembly		112610-0-01									
B- 3	Thread Take-up Lever		112578-0-01									
B-30	Pulley		144614-0-01									
B-32	Screw		104478-0-01									
B-34	Needle Clamp		112599-0-01	112000-0-01	114947-0-01	112601-0-01	116489-0-01	116491-0-01	116490-0-01	116488-0-01	116492-0-01	
B-36	Needle DP x 5		107415-0-11	107415-0-14								
B-37	Needle Bar Crank Rod Assembly		112587-1-01									
B-37-1	Needle Bar		112591-0-01									
B-37-6	Needle Bar Support		112589-1-00									
C- 4	Presser Bar Guide Assembly		180950-0-01									
C-11	Presser Bar Bushing, Lower		112763-0-01									
C-13	Presser Foot		117281-0-01	112638-0-01	112642-0-01	114948-0-01	112645-0-01	116502-0-01	116498-0-01	116499-0-01	116500-0-01	116501-0-01
C-15	Knee Lifter Lever		112625-0-01									
C-18	Spring		112629-0-01									
C-22	Knee Lifter Connecting Lever		112627-0-01									
C-23	Screw		112628-0-01									
C-24	Knee Lifter Connecting Rod		112632-0-01									
C-25	Pin		114909-0-00									
C-26	Collar		112634-0-02									
C-27	Screw		104908-0-04									
C-28	Knee Lifter Roller Bracket		151609-0-01									
C-29	Knee Lifter Assembly		113380-0-01									
C-30	Screw		106030-0-01									
C-31	Finger Guard Supporter		☆ 151191-0-01									
C-32	Screw		☆ 144458-0-01									
C-33	Finger Guard		☆ 150917-0-01									
C-34	Screw		☆ 149177-0-01									
D-13	Length Control Plate		151508-0-01									
D-18	Feed Regulator Lever Shaft		151080-0-01									

The parts Nos. marked with ☆ are for 80306 . 80314 and 80512 type specification.



Ref. No.	Name of Parts	Sub Class	-5				-403		-405	-503		-505
		Gauge	1.1/2	1/4	1/8	5/16	3/16	1/4	1/4	3/16	1/4	1/4
A-15	Upper Tension Control Assembly	144678-0-01	148011-1-01									
A-15-9	Tension Spring	118317-0-01	148672-0-01									
A-28	Arm Thread Guide, Lower	112715-0-01										
A-29	Screw	108960-0-04										
A-30	Felt	114941-0-01										
A-31	Pipe	112714-0-00										
A-32	Thread Release Shaft	144823-0-01										
A-35	Needle Plate (Assembly)	118945-0-01	117367-0-01	117369-0-01	144882-0-01	148718-0-01	148722-0-01	148724-0-01	148718-0-01	148722-0-01	148724-0-01	
A-36	Screw	100032-0-03										
A-39	Slide Plate, Left	145721-0-01	112606-0-01									
A-41	Slide Plate Front Assembly	112610-0-01										
B- 3	Thread Take-up Lever	112578-0-01	140525-0-01			112578-0-01						
B-30	Pulley	144614-0-01										
B-32	Screw	104478-0-01										
B-34	Needle Clamp	118944-0-01	112600-0-01	114947-0-01	112601-0-01	112599-0-01	112600-0-01		112599-0-01	112600-0-01		
B-36	Needle DP x 5	107415-0-14	107415-0-22			107415-0-14		107415-0-22	107415-0-14		107415-0-22	
B-37	Needle Bar Crank Rod Assembly	112587-1-01										
B-37-1	Needle Bar	112591-0-01										
B-37-6	Needle Bar Support	112589-1-00										
C- 4	Presser Bar Guide Assembly	180950-0-01										
C-11	Presser Bar Bushing, Lower	112763-0-01										
C-13	Presser Foot	118946-0-01	112642-0-01	114948-0-01	112645-0-01	148687-0-01	148693-0-01	148695-0-01	148687-0-01	148693-0-01	148695-0-01	
C-15	Knee Lifter Lever	112625-0-01										
C-18	Spring	112629-0-01										
C-22	Knee Lifter Connecting Lever	112627-0-01										
C-23	Screw	112628-0-01										
C-24	Knee Lifter Connecting Rod	112632-0-01										
C-25	Pin	114909-0-01										
C-26	Collar	112634-0-02										
C-27	Screw	104908-0-04										
C-28	Knee Lifter Roller Bracket	151609-0-01										
C-29	Knee Lifter Assembly	113380-0-01										
C-30	Screw	106030-0-01										
C-31	Finger Guard Supporter											
C-32	Screw											
C-33	Finger Guard											
C-34	Screw											
D-13	Length Control Plate	151508-0-01	151507-0-01			151508-0-01		151507-0-01	151508-0-01		151507-0-01	
D-18	Feed Regulator Lever Shaft	151080-0-01										





Ref. No.	Name of Parts	Sub Class	-5				-403		-405	-503		-505
		Gauge	1.1/2	1/4	1/8	5/16	3/16	1/4	1/4	3/16	1/4	1/4
D-19	Link Assembly			143608-0-01								
D-20	Screw			014760-6-22								
D-21	Reverse Lever			118752-0-01								
D-22	Screw			015771-0-12								
D-23	Reverse Lever Stopper			118865-0-01								
D-24	Screw			009680-7-12								
D-25	Spring			143609-0-01						143609-0-01		
D-32	Feed Regulator Arm	148499-0-01		148500-0-01				148499-0-01	148500-0-01	148499-0-01	148500-0-01	
D-38	Level Feed Connecting Rod Assembly			143611-0-01								
D-50	Feed Rock Shaft			149001-0-01								
D-52	Feed Bar			151081-0-01								
D-54	Feed Bar Shaft			148977-0-01								
D-62	Feed Dog	118947-0-01	112660-0-01	114951-0-01	112661-0-01		148702-0-01	148704-0-01	148705-0-01	1148702-0-01	148704-0-01	148705-0-01
E- 1	Lower Shaft			151082-0-01								
E- 6	Vertical Feed Eccentric Wheel Assembly			181486-0-01					181486-0-01			181486-0-01
E-12	Timing Belt Wheel Lower Assembly			180164-0-01						180164-0-01		
E-13	Screw			015771-2-12								
E-37	Rotary Hook	112691-0-01		144903-0-01								
E-37-2	Inner Rotary Hook Assembly	151138-0-01		151139-0-01								
E-37-2-1	Adjusting Spring	151145-0-01		151146-0-01								
E-38	Bobbin			112781-0-01								
E-39	Rotary Hook Base, Left			112685-0-01								
E-42	Washer			100197-0-01								
E-43	Screw			105351-0-02								
E-45	Oil Gauge			112757-0-01								
E-46	Oil Pipe			115287-0-01								
E-51	Rotary Hook Base, Right			112701-0-01								
F- 1	Oil Reservoir Plate Assembly			112762-0-01								
F-23	Oil Tube			112737-0-01								
F-24	Wick 2.5φ x 400			112738-0-00								
F-25	Oil Tube			143661-0-00								
F-26	Wick			143660-0-00								
F-27	Oil Tube			151084-0-00								
F-28	Wick			143662-0-00								
F-29	Oil Tube			143669-0-00								
F-30	Wick			143668-0-00								
F-31	Oil Tube			143669-0-00								
F-32	Wick			143668-0-00								
F-33	Out Tube			143671-0-00								
F-34	Wick			143670-0-00								
F-37	Oil Pipe Supporter			151083-0-01								

Ref. No.	Name of Parts	Sub Class	-3									
		Gauge	3/16	3/16	1/4	1/8	5/16	5/32	3/8	1/2	5/8	1-1/4
F-38	Oil Felt		112741-0-01									
F-51	Oil Pan Plate Assembly	117200-0-01										
F-52	Spring	117204-0-01										
F-53	Stop Ring	117205-0-01										
F-54	Wick Presser Plate	117203-0-01										
F-55	Screw	009671-0-12										
G- 1	Arm Thread Guide, Center											
G- 3	Thread Guide Assembly											
G- 8	Cord Holder											
G- 9	Screw											
G-32	Knee Lifter Assembly											
G-33	Tension Control Plate Assembly											
G-33-13	Tension Spring											
G-34	Spring											
H- 7	Knee Lifter Connecting Rod											
H- 8	Pulley											
H- 9	Pulley											
H-10	Washer											
H-11	Bolt											
H-13	Vertical Feed Eccentric Wheel Assembly											
H-19	Spring											
H-21	Bobbin Tension Spring											
H-22	Rotary Hook											
H-27	Timing Belt Pulley Lower Assembly											
J- 4	Thread Presser Spring											
J-46	Tension Release Rock Lever Assembly											
J-58	Stopper											
J-59	Washer											
J-60	Screw											
K- 9	Spring											
K-18	Thread Wiper Solenoid											
K-27	Switch											
K-33	Thread Wiper Solenoid											
K-34	Switch											
L- 3	Spring											
L-15	Knife Driving Cam											
L-29	Bolt											
L-32	Reverse Solenoid Assembly											
L-34	Screw											



Ref. No.	Name of Parts	Sub Class	-5				-403		-405		-503		-505
		Gauge	1.1/2	1/4	1/8	5/16	3/16	1/4	4/1	3/16	1/4	1/4	
F-38	Oil Felt		112741-0-01										
F-51	Oil Pan Plate Assembly												
F-52	Spring												
F-53	Stop Ring												
F-54	Wick Presser Plate												
F-55	Screw												
G- 1	Arm Thread Guide, Center						112658-0-01			112658-0-01			
G- 3	Thread Guide Assembly							148656-0-01				148656-0-01	
G- 8	Cord Holder						148818-0-01						
G- 9	Screw						009670-6-12						
G-32	Knee Lifter Assembly						148674-0-01						
G-33	Tension Control Plate Assembly						181756-0-01	181755-0-01		181756-0-01		181755-0-01	
G-33-13	Tension Spring						118317-0-01	148672-0-01		118317-0-01		148672-0-01	
G-34	Spring									149768-0-01			
H- 7	Knee Lifter Connecting Rod						148484-0-01						
H- 8	Pulley						148617-0-01						
H- 9	Pulley									149062-0-01			
H-10	Washer									025770-2-32			
H-11	Bolt									149569-0-01			
H-13	Vertical Feed Eccentric Wheel Assembly						148804-0-01			148804-0-01			
H-19	Spring						148726-0-01						
H-21	Bobbin Tension Spring						148602-0-01	148601-0-01		148602-0-01		148601-0-01	
H-22	Rotary Hook						151016-0-01	148618-0-01		151016-0-01		148618-0-01	
H-27	Timing Belt Pulley Lower Assembly						148803-0-01						
J- 4	Thread Presser Spring						148593-0-00	148594-0-01		148593-0-01		148594-0-01	
J-46	Tension Release Rock Lever Assembly						148619-0-01						
J-58	Stopper									149282-0-01			
J-59	Washer									100645-0-03			
J-60	Screw									009681-0-12			
K- 9	Spring						148526-0-01	148527-0-01		148526-0-01		148527-0-01	
K-18	Thread Wiper Solenoid									BROTHER MOTOR SPEC. 148509-0-01			
K-27	Switch									BROTHER MOTOR SPEC. 151884-0-00			
K-33	Thread Wiper Solenoid									EFKA MOTOR SPEC. 149246-0-01			
K-34	Switch									EFKA MOTOR SPEC. 151885-0-00			
L- 3	Spring						148571-0-01	148569-0-01		148571-0-01			
L-15	Knife Driving Cam						148540-0-01	148541-0-01					
L-29	Bolt									018061-6-22			
L-32	Reverse Solenoid Assembly						BROTHER MOTOR SPEC. 148636-0-01						
L-34	Screw									009782-5-12			

Ref. No.	Name of Parts	Sub Class	Gauge	-3										
				-1	3/16	1/4	1/8	5/16	5/32	3/8	1/2	5/8	1-1/4	
L-37	Screw													
L-47	"O" Reset Solenoid Assembly													
L-56	Screw													
L-57	6P Connector													
L-58	Connector Cap													
L-61	Nylon Connector													
L-62	Connector Cap													
L-66	Thread Trimmer Solenoid Assembly													
L-68	Thread Trimmer Solenoid Assembly													
L-69	"O" Reset Solenoid Assembly													
L-70	Reverse Solenoid Assembly													
M- 1	Synchronizer Assembly #6-1													
M- 2	Screw													
M- 4	Slip Ring Support													
M- 5	Screw													
Q- 1	Valve Box Assembly													
Q- 2	Screw													
R- 2	Presser Foot Lifter Cord Assembly													
R- 3	Screw													
R- 4	Washer													
R- 5	Washer													
R- 6	Nut													
R- 7	Bread Band													
Z- 7	Needle DP x 5		107415-0-11					107415-0-14						
Z- 8	Bobbin							112781-0-01						
Z-10	Flet							114941-0-01						
Z-11	Head Rest							100477-0-01						
Z-23	Head Hinge													
Z-24	Washer													
Z-25	Screw													
Z-26	Earth Wire													
Z-27	Spanner													
Z-28	Spanner 3													
Z-29	Spanner													
Z-30	Spring													
Z-31	Head Rest													



Ref. No.	Name of Parts	Sub Class Gauge	-3				-5		-403		-405	-503		-505
			1.1/2	1/4	1/8	5/16	3/16	1/4	4/1	3/16	1/4	1/4		
L-37	Screw		148764-0-01											
L-47	"O" Reset Solenoid Assembly		BROTHER MOTOR SPEC. 148648-0-01											
L-56	Screw		110171-0-01											
L-57	6P Connector		BROTHER MOTOR SPEC. 146118-0-00											
L-58	Connector Cap		BROTHER MOTOR SPEC. 145596-0-01											
L-61	Nylon Connector		BROTHER MOTOR SPEC. 145681-0-00											
L-62	Connector Cap		BROTHER MOTOR SPEC. 146119-0-00											
L-66	Thread Trimmer Solenoid Assembly		BROTHER MOTOR SPEC. 148542-0-01											
L-68	Thread Trimmer Solenoid Assembly		EFKA MOTOR SPEC. 149245-0-01											
L-69	"O" Reset Solenoid Assembly		EFKA MOTOR SPEC. 149244-0-01											
L-70	Reverse Solenoid Assembly		EFKA MOTOR SPEC. 149243-0-01											
M- 1	Synchronizer Assembly #6-1		BROTHER MOTOR SPEC. 220067-0-01											
M- 2	Screw		BROTHER MOTOR SPEC. 009711-4-12											
M- 4	Slip Ring Support		EFKA MOTOR SPEC. 148825-0-01											
M- 5	Screw		EFKA MOTOR SPEC. 009711-4-12											
Q- 1	Valve Box Assembly		BROTHER MOTOR SPEC. 149153-0-01											
Q- 2	Screw		BROTHER MOTOR SPEC. 100666-0-02											
R- 2	Presser Foot Lifter Cord Assembly		BROTHER MOTOR SPEC. 146160-0-01											
R- 3	Screw		BROTHER MOTOR SPEC. 002303-0-06											
R- 4	Washer		BROTHER MOTOR SPEC. 025030-2-33											
R- 5	Washer		BROTHER MOTOR SPEC. 028030-2-43											
R- 6	Nut		BROTHER MOTOR SPEC. 021300-1-03											
R- 7	Bead Band		BROTHER MOTOR SPEC. 144189-0-01											
Z- 7	Needle DP x 5		107415-0-14	107415-0-22				107415-0-14	107415-0-22	107415-0-14	107415-0-22			
Z- 8	Bobbin		112781-0-01				148603-0-01							
Z-10	Felt		114941-0-01											
Z-11	Head Rest		100477-0-01											
Z-23	Head Hinge		150557-0-01											
Z-24	Washer		025680-2-34											
Z-25	Screw		009680-6-13											
Z-26	Earth Wire		145946-0-01											
Z-27	Spanner		149570-0-01											
Z-28	Spanner 3		142721-0-01											
Z-29	Spanner		142002-0-01											
Z-30	Spring		148570-0-01		149175-0-01									
Z-31	Head Rest		149010-0-00											

Ref. No.	Sub Class		-1	-3	-5	-403	-405	-503	-505
	Name of Parts	Q'ty							
E-14	Screw	Q'ty		1			2		1
F-42	Tube Holder	Q'ty		4				3	
F-43	Screw	Q'ty		4				3	
F-44	Tube Holder	Q'ty		2				1	
F-45	Screw	Q'ty		2				1	
G- 6	Tube Holder	Q'ty					2		3
G- 7	Screw	Q'ty					2		3
L- 3	Spring	Q'ty					2		1

Ref. No.	Sub Class		-400			-500			
	Name of Parts	Volt	200V	380V	400V	200V	220V	380V	400V
S- 1	Control Box Assembly	3	219208-0-01	219707-0-01	219704-0-01	219946-0-01	220091-0-01	220093-0-01	220095-0-01
A- 1-4	Transformer	3	219210-0-00	219708-0-00	219705-0-00	219210-0-00	220097-0-00	219708-0-00	219705-0-00
T- 6	Motor Assembly	3	218830-0-01	219497-0-01	219507-0-01	218830-0-01	219972-0-01	219497-0-01	219507-0-01
T- 6	Motor Assembly	3							
T- 6-44	Sub Motor Assembly	3	218906-0-01						

Ref No.	Name of Parts	Parts No.	Sewing Speed			
			50Hz		60Hz	
			High Speed	Slow Speed	High Speed	Slow Speed
T-7	Pulley G 50	212041-0-01			2290	110
T-7	Pulley G 55	212042-0-01			2520	120
T-7	Pulley G 60	212425-0-01	2280	109	2750	130
T-7	Pulley G 65	211003-0-01	2470	118	2950	140
T-7	Pulley G 70	213073-0-01	2660	127	3150	116
T-7	Pulley G 75	210236-0-01	2850	136	3400	126
T-7	Pulley G 80	212426-0-01	3040	113	3600	133
T-7	Pulley G 85	210237-0-01	3230	120	3800	140
T-7	Pulley G 90	211546-0-01	3420	127		
T-7	Pulley G 95	214163-0-01	3600	133		
T-7	Pulley G 100	210238-0-01	3800	141		



# I N D E X

Parts No.	Ref. No.	Remark	Parts No.	Ref. No.	Remark	Parts No.	Ref. No.	Remark	Parts No.	Ref. No.	Remark
001630-4-02	J- 6		009711-4-12	L-14					100242-0-03	D-61	
001670-6-12	F-15			M- 2		025040-1-35	T- 6-98-26		100248-0-01	B-22	
002300-5-05	L-46			M- 5		025040-1-73	T- 6-12		100250-0-01	B-15	
002300-6-03	L-50			N-58		025040-2-33	K- 3		100251-0-01	B-12	
002300-8-05	S- 1-18		009711-4-13	K-14			Q- 1-18			E-17	
002301-0-03	Q- 1-10		009711-6-12	N-19		025040-2-35	S- 1- 6		100260-0-01	C- 3	
002303-0-06	R- 3			N-63		025040-3-35	M- 1- 6		100289-0-03	L- 9	
002400-6-05	T- 6-98-14		009761-4-12	D-57			M- 1-15		100320-0-02	E-53	
002400-8-03	L-64		009781-4-12	L-24			T- 6-98-15		100328-0-01	D-16	
	Q- 1-19		009781-8-12	B-47		025050-1-34	Q- 1- 6		100366-0-02	Z-13- 2	
002401-0-63	T- 6-10			D-45		025050-1-35	T- 6-55		100401-0-01	Z-13- 9	
002500-8-06	T- 6-45		009782-5-12	L-34		025050-2-33	Z-12- 3		100477-0-01	Z-11	
002501-0-64	Q- 1- 3		011060-6-13	T- 6-19		025050-2-35	T- 6- 2		100645-0-03	E-49	
	Q- 1- 5		011802-0-12	L-27		025050-3-35	T- 9			J-59	
002501-6-05	T- 6-38		012061-2-22	T- 6-98-12		025060-1-32	D-58		100657-0-01	Z-13- 6	
	T- 6-68		012061-8-22	T- 6-44-11		025060-3-35	M- 1-11		100659-0-01	Z-13-14	
002503-5-05	T- 6-89		013080-8-13	T- 6-13					100661-0-01	Z-13-18	
005671-2-12	E-11		013761-4-10	B-19		025100-2-36	T- 6-29		100662-0-01	Z-13-22	
007401-0-13	K- 2			B-23		025630-1-32	J- 5		100666-0-02	Q- 2	
007500-6-02	L-31			B-31		025680-2-34	Z-24			Z-14	
007500-8-02	L-35			D-41		025710-2-32	E-25			Z-15- 2	
007501-0-03	Z-12-14			D-49			N-18		100887-0-01	Z- 5	
008400-5-64	Q- 1- 8		013710-7-12	N-13		025750-1-32	Z-15- 3		101268-0-03	B-48	
008400-8-06	T- 6- 9		013771-2-12	B-27		025770-2-32	H-10		101572-1-01	Z- 2	
009660-4-12	F-41			E-14		028030-2-43	Q- 1-13		101706-0-01	B-11	
009660-7-12	N-43		013780-7-10	E- 9			R- 5			D-34- 2	
009670-5-12	B-52		014061-0-22	T- 6-97			S- 1-17			D-47	
	F-36		014760-6-22	D-20		028040-2-43	T- 6-11			E-18	
	F-43			J-56			T- 6-61		102731-0-04	B-37- 8	
	F-45		014770-6-22	J-13			T- 6-98-13			H- 1- 8	
	G-29			L-17		028050-2-43	Q- 1-15		103896-0-02	Z- 9	
009670-6-12	A-11			N-31			T- 6-26		104478-0-01	B-32	
	A-18			N-33			T- 6-46		104908-0-04	C-27	
	F- 9		015771-0-12	D-22			T- 6-56			D-51	
	G- 7			J-49			Z-12-11		105161-0-02	E-20	
	G- 9		015771-2-12	B-26		028060-2-43	M- 1-12			N-48	
009670-8-12	B-37- 3			E-13					105173-0-04	N-44	
	C-10		016500-8-22	Q- 1-17- 7		028060-2-43	T- 6-98-18		105234-0-01	E-47	
	E-21		017502-8-03	Z-12- 4		028080-2-43	T- 3		105288-0-01	H- 3	
	H- 1- 3			Z-12-18		028100-2-43	T- 6-30		105351-0-02	B-50	
	N-46		018061-6-22	L-29		028680-2-42	Z-15- 7			E-43	
	N-49		018401-4-22	T- 6-60		028680-2-43	E-48		106030-0-01	C-30	
009671-0-12	F-55		018502-2-33	T- 6-76		031451-6-03	S- 1-13		106120-0-02	A- 4	
	K-25		018502-5-22	T- 6-57		031452-2-03	Z-12-16		106640-0-01	F-12	
009679-3-12	F- 4		021060-3-05	T- 6-44-12			Z-12-20		107030-0-01	B-37- 9	
	K-22			T- 6-73		031624-0-05	S- 4			H- 1-10	
	Z-13-20			T- 6-98- 9		047501-2-42	C-28- 3		107155-0-01	E-28	
009680-6-13	Z-25		021080-1-06	T- 4		048030-3-42	L-20		107231-0-02	A- 6	
009680-7-12	C- 4- 2		021100-2-06	T- 6-28			N-40		107278-0-02	D-56	
	D-24		021300-1-03	Q- 1-14			N-56- 6		107407-0-03	K- 4	
	H- 4- 2			R- 6		048040-3-42	L-40			K- 7	
009680-8-12	Z-15- 8		021500-1-03	Z-12- 6- 3			N-14		107415-0-11	B-36	
009681-0-12	D-35- 3			Z-12-12			N-25			Z- 7	
	J-60			Z-12-15			N-61		107415-0-14	B-36	
009681-0-13	A- 9		021500-1-63	Q- 1-16		048060-3-42	D-43			Z- 7	
009681-0-14	A-16		021660-1-03	D-55		048070-3-42	D- 3		107415-0-22	B-36	
009681-4-14	K-28		021670-1-02	A-15- 7		048080-3-42	K-30			Z- 7	
009681-6-13	A- 8			G-33-25		072060-8-60	T- 6-44- 3		107419-0-02	L-36	
009710-8-12	D-27			J-34			T- 6-70		107794-0-01	E-32	
	F-18			N-55		072620-1-61	T- 6-86			E-34	
	J-11		025030-1-33	Q- 1-11		072620-2-60	T- 6-51- 4		108254-0-01	A-15-20	
	L-60		025030-2-32	L-45		072620-3-60	T- 6-33			G-33- 5	
009711-0-12	F-39		025030-2-33	L-49		072620-4-60	B-29		108263-0-01	A-15-11	
	J-17			R- 4		081016-0-70	F-47			G-33-15	
	L- 2		025030-3-35	M- 1- 3		100022-0-05	L- 5		108264-0-01	A-15-10	
	L-65					100032-0-02	E-44		108265-0-01	A-15- 8	
	N-35			S- 1-16		100032-0-03	A-36			G-33- 7	
009711-2-12	N- 2		025040-1-35	M- 1- 9		100064-0-02	A-19		108266-0-01	A-24	
009711-4-12	J-19					100078-0-03	L-26		108546-0-01	D-19- 2	
	J-54					100197-0-02	E-42		108549-0-01	D-10	



Parts No.	Ref. No.	Remark	Parts No.	Ref. No.	Remark	Parts No.	Ref. No.	Remark	Parts No.	Ref. No.	Remark
108960-0-04	A-25		112659-0-01	D-62		113362-0-01	E- 4		118746-0-01	D- 6	
	A-27		112660-0-01	D-62		113380-0-01	C-29		118747-0-01	D- 8	
	A-29		112661-0-01	D-62		113386-0-00	A-37		118752-0-01	D-21	
	G- 2		112666-0-00	E- 8- 1		113524-0-01	F-13		118837-0-01	Z- 3	
109714-0-00	F-49		112667-0-01	E- 8- 2		113526-0-01	F- 8		118853-0-01	D-9- 33	
	Z-19		112668-0-01	E-10		114297-0-01	F- 7		118865-0-01	D-23	
110161-0-06	E-26		112684-0-01	E- 6- 2			F-35		118944-0-01	B-34	
110171-0-01	J-41			E-16		114483-0-01	Z-16		118945-0-01	A-35	
	L-56			H-13- 2		114486-0-01	F-50		118946-0-01	C-13	
110436-0-01	Z- 1		112685-0-01	E-39		114680-0-01	B-21		118947-0-01	D-62	
112656-0-01	D-59		112686-0-01	E-41		114693-0-01	B- 6		118954-0-00	D-38- 2	
112072-0-01	D- 7		112687-0-01	E-31		114909-0-00	C-25			H-15- 2	
112560-0-01	A- 7		112690-0-01	E-33		114941-0-01	A-30		123882-0-01	J-45	
112561-0-02	A- 5		112691-0-01	E-37			Z-10		140525-0-01	B- 3	
112566-0-01	A-10		112692-0-01	E-23		114947-0-01	B-34		140527-0-01	A-12	
112569-0-01	Z-21		112694-0-01	E-22		114948-0-01	C-13		140538-0-00	Q- 1-17-10	
112572-0-01	B-30		112695-0-01	E-27		114950-0-01	A-35		140539-0-00	Q- 1-17- 8	
112572-0-01	B-20		112696-0-00	A-14		114951-0-01	D-62		140540-0-00	Q- 1- 1	
112573-0-01	B-17			E-29		115177-0-01	J-42		140542-0-01	Q- 1-17- 5	
112574-0-00	B-13		112697-0-01	E-19		115249-0-01	E- 3		140543-0-00	Q- 1-17-13	
112576-0-01	B-16		112698-0-01	E- 8		115287-0-00	E-46		140544-0-00	Q- 1-17-12	
112577-0-01	B- 8		112699-0-01	E-35		116010-0-01	A-42		140620-0-01	L-25	
112578-0-01	B- 3		112700-0-01	E-36		116283-0-01	D-63			N-17	
112579-0-01	B- 1		112701-0-01	E-51		116323-0-01	B-35			N-23	
112586-0-01	B-24		112702-0-01	E-52		116488-0-01	B-34			N-64	
112587-0-01	B-37		112709-0-01	A-17		116489-0-01	B-34		140678-0-00	Q- 1- 2- 5	
112589-1-00	B-37- 6		112712-0-01	A-15-16		116490-0-01	B-34		140680-0-00	Q- 1-17- 4	
112590-0-01	B-37- 7			G-33-12		116491-0-01	B-34		140682-0-01	Q- 1-17- 2	
	H- 1- 7		112714-0-00	A-31		116492-0-01	B-34		140693-0-00	R- 2- 7	
112591-0-01	B-37- 1		112715-0-01	A-28		116498-0-01	C-13		140948-0-01	R- 2- 1	
112592-0-01	B-37- 2		112716-0-01	F-16		116499-0-01	C-13		140950-0-00	R- 2- 2	
	H- 1- 2		112717-0-01	F-17		116500-0-01	C-13		141439-0-01	N-11	
112593-0-01	B-37- 4		112719-0-01	B-40		116501-0-01	C-13		141494-0-01	J-21	
	H- 1- 4		112720-0-01	B-40		116502-0-01	C-13			L-11	
112594-0-01	B-39		112721-0-01	B-37- 5		116503-0-01	A-35			N- 6	
112595-0-00	B-49			H- 1- 5		116504-0-01	A-35		141748-0-01	J-47	
112596-0-01	B-44		112723-0-01	F-10		116505-0-01	A-35		142002-0-01	Z-29	
112597-0-01	B-45		112724-0-01	F- 6		116506-1-01	A-35		142037-0-00	Q- 1-17- 9	
112598-0-01	B-46		112725-0-01	F- 5		116507-0-01	A-35		142038-0-01	Q- 1-17-11	
112599-0-01	B-34		112728-0-01	B-38		116508-0-01	D-62		142268-0-01	G- 6	
112600-0-01	B-34		112730-0-01	F- 3		116509-0-01	D-62		142349-0-00	Q- 1- 2- 1	
112601-0-01	B-34		112734-0-01	B-18		116510-1-01	D-62		142443-0-01	Z- 4	
112603-0-01	A-35		112735-0-00	B-10		116511-0-01	D-62		142721-0-01	Z-28	
112604-0-01	A-35		112735-0-01	B- 4		116512-0-01	D-62		142746-0-02	D-14	
112605-0-01	A-35		112736-0-00	F-22		116558-0-01	F-46		142747-0-02	D-15	
112606-0-01	A-39		112737-0-01	F-23		116699-0-00	B-42		143488-0-01	R- 2- 3	
			112738-0-00	F-24		117134-0-01	D-62		143489-0-01	R- 2- 4	
112607-0-01	A-40		112739-0-01	B-51		117158-0-01	A-35		143549-0-00	K-18- 3	
112610-0-01	A-41		112741-0-01	F-38		117160-0-01	A-36			K-27- 3	
112614-0-01	C- 1		112743-0-01	F-42			J-31			L-32- 3	
112615-0-01	C- 2		112744-0-01	F-44		117200-0-01	F-51			L-47- 3	
112616-0-01	C- 9		112745-0-01	G-28		117203-0-01	F-54			L-66- 4	
112618-0-01	C- 7		112751-0-02	A-38		117204-0-01	F-52			R- 2- 5	
112619-0-01	C- 8		112753-0-01	F-20		117205-0-01	F-53		143591-0-01	D-53	
112623-0-01	C-21		112754-0-01	F-19		117281-0-01	C-13		143594-0-01	D-35- 2	
112624-0-01	C-19		112755-0-01	E-40		117367-0-01	A-35		143597-0-01	D-37	
112625-0-01	C-15		112756-0-01	E-50		117369-0-01	A-35		143598-0-01	D-11	
112626-0-01	C-17		112757-0-01	E-45		117666-0-01	N-54		143608-0-01	D-19	
112627-0-01	C-22		112758-0-01	F-21		117963-0-01	Z-13		143609-0-01	D-25	
112628-0-01	C-23		112759-0-01	D-60		117969-0-01	Z-13-16		143610-0-01	D-26	
112629-0-01	C-18		112760-0-01	B-28		117970-0-01	Z-13- 5		143611-0-01	D-38	
112630-0-01	C-16		112762-0-01	F- 1		118170-0-01	C-20		143612-0-00	D-38- 1	
112631-0-01	C- 6		112763-0-01	C-11		118171-0-01	B- 5		143613-0-01	D-38- 3	
112632-0-01	C-24		112764-0-01	B-43		118317-0-01	A-15- 9			H-15- 3	
112634-0-02	C-26		112781-0-01	E-38			G-33-13		143616-0-01	D-42	
112636-0-01	C-28- 2			Z- 8		118320-0-01	A-15-15		143657-0-00	F-11	
							G-33-11		143660-0-00	F-26	
112638-0-01	C-13		113014-0-00	B- 9				143661-0-00	F-25		
112642-0-01	C-13		113024-0-00	B- 7		118713-0-01	D-29		143662-0-00	F-28	
112645-0-01	C-13		113050-0-01	C-14			L-52		143662-0-00	F-28	
	G- 1		113074-0-01	D-46			N-10		143668-0-00	F-30	



Parts No.	Ref. No.	Remark	Parts No.	Ref. No.	Remark	Parts No.	Ref. No.	Remark	Parts No.	Ref. No.	Remark
143668-0-00	F-32		148483-0-01	C- 5		148584-0-01	J-20- 2		148687-0-01	C-13	
143669-0-00	F-29		148484-0-01	H- 7		148585-0-01	J-20		148693-0-01	C-13	
	F-31		148486-0-01	H- 6		148587-0-01	L-10		148695-0-01	C-13	
143670-0-00	F-34		148487-0-01	D-28		148589-0-01	L- 4		148702-0-01	D-62	
143671-0-00	F-33		148488-0-01	D- 2		148591-0-01	L- 6		148704-0-01	D-62	
143673-0-01	F-40		148489-0-01	D- 5		148592-0-01	L- 7		148705-0-01	D-62	
143766-0-01	D- 1		148490-0-01	H-16		148593-0-00	J- 4		148712-0-01	A-35	
143910-0-01	Z-22		148491-0-01	H-17		148594-0-00	J- 4		148714-0-01	A-35	
143959-1-04	Q- 1- 2		148492-0-01	H-18		148595-1-01	H- 1		148716-0-01	A-35	
143960-1-01	Q- 1- 2- 3		148493-0-01	D-40		148596-1-00	H- 1- 6		148718-0-01	A-35	
144189-0-01	R- 7		148494-0-01	D-48		148597-0-01	H- 1- 1		148722-0-01	A-35	
144222-0-01	Z-32		148495-0-01	D-44		148598-0-01	H- 2		148724-0-01	A-35	
144458-0-01	C-32		148496-0-00	H-15- 1		148599-0-01	G-13		148726-0-01	H-19	
144614-0-01	B-30		148499-0-01	D-32		148601-0-01	H-21		148728-0-01	H-25	
144678-0-01	A-15		148500-0-01	D-32		148602-0-01	H-21		148729-0-01	G-30	
144680-0-01	A-15-22		148501-0-01	D-30		148603-0-01	H-20		148730-0-01	G-16	
	G-33- 9		148502-0-00	E- 7			Z- 8		148731-0-00	G-17	
144681-0-01	A-15-23		148503-0-00	E- 2		148604-0-00	G-14		148732-0-01	G-31	
	G-33- 8		148505-0-01	H-12		148605-0-01	H- 5		148733-0-01	G-20	
144682-0-01	A-15-21		148508-0-01	K-15		148606-0-01	J-51			G-26	
	G-33- 6		148509-0-01	K-18		148607-0-01	J-48		148734-0-00	G-27	
144683-0-01	A-15-14		148511-0-01	K-18-2 · 33-2		148608-0-01	J-52		148735-0-01	G-22	
	G-33-10		148513-0-01	K- 1		148609-0-01	J-57		148736-0-00	G-23	
144685-0-01	A-15- 3		148514-0-01	K-21		148610-0-01	G-15		148737-0-01	G-24	
144686-0-01	A-15- 5		148515-0-01	K-16		148611-0-01	G-10		148738-0-00	G-25	
144687-0-01	A-15- 6		148516-0-01	K- 6		148612-0-01	K-32		148740-0-00	G-21	
144688-0-01	A-15- 4		148517-0-00	K- 8		148613-0-01	K-32- 1		148741-0-01	G-18	
144689-0-01	A-15- 2		148518-0-00	K- 5		148614-0-01	G- 4		148742-0-00	G-19	
144703-0-01	A-15-13		148521-0-01	K-17		148615-0-01	M- 3		148743-0-01	D-36	
144704-0-01	A-15-12		148526-0-01	K- 9		148617-0-01	H- 8		148744-0-01	L-44	
144823-0-01	A-32		148527-0-01	K- 9		148618-0-01	H-22		148762-0-01	F-14	
144882-0-01	A-35		148529-0-01	K-13		148623-0-01	J-44		148763-0-01	L-51	
144903-0-01	E-37		148530-0-01	K-12		148625-0-01	J-39		148764-0-01	L-37	
144910-0-01	Q- 1-12		148531-0-01	J-10		148628-0-01	J-37		148765-0-01	L-42	
145277-1-03	Z-17		148535-0-01	J- 7			J-40		148767-0-01	L-54	
145328-0-01	D-35- 4		148536-0-01	J- 8		148629-0-01	J-38		148768-0-01	J-35	
145446-0-01	Z-13-10		148537-0-01	J- 9		148630-0-01	J-36		148770-0-01	K-10	
145502-0-01	D-17		148538-0-01	J- 2		148631-0-01	J-32		148771-0-01	D-35	
145596-0-01	L-58		148539-0-01	J- 3		148632-0-01	J-33		148801-0-01	H-15	
145681-0-00	L-61		148540-0-01	L-15		148633-0-01	J-29		148802-0-01	D-39	
145721-0-01	A-39		148541-0-01	L-15		148634-0-01	J-30		148803-0-01	H-27	
145827-0-01	Q- 1-17- 3		148542-0-01	L-66		148635-0-01	J-28		148804-0-01	H-13	
145946-0-01	Z-26		148545-0-01	L-66-2 · 68-2		148636-0-01	L-32		148818-0-01	G- 8	
146080-0-00	K-20		148546-0-01	K-19		148637-0-01	L-32-2 · 70-2		148821-0-01	H-28	
	K-26			L-67		148638-0-01	J-55		148825-0-01	M- 4	
146118-0-00	L-57			N-37		148640-0-01	J-53		148835-0-01	H- 4	
146119-0-00	L-62		148547-0-01	J-22		148641-0-01	L-55		148882-0-01	Z-20	
146120-0-01	K-23		148548-0-01	L-18		148642-0-01	L-41		148890-1-01	Z-18	
146124-0-01	K-31		148553-0-01	L-12		148643-0-01	L-33		148968-0-01	Q- 1- 4	
146125-0-01	K-29		148554-0-01	L- 8		148648-0-01	L-47		148977-0-01	D-54	
146128-0-00	K-32- 2		148555-0-01	J-23		148650-0-01	L-47-2 · 69-2		149001-0-01	D-50	
146141-0-01	B-14		148557-0-01	J-26		148651-0-01	L-48		149010-0-00	Z-31	
146153-0-01	N- 9		148559-0-00	J-24		148652-0-01	L-38		149019-0-01	N-15	
	N-24		148560-0-01	L-30		148653-0-01	L-43		149023-0-01	N-16	
	N-60		148561-0-01	L-63		148654-0-01	J-43		149024-0-01	N- 8	
146160-0-01	R- 2		148562-0-01	L-19		148655-0-01	L-59		149025-0-01	N- 7	
146171-0-00	Q- 1-22		148567-0-01	L-21		148656-0-01	G- 3		149027-0-01	N- 4	
146598-0-01	A- 2		148568-0-01	L-22		148662-0-01	G-33-21		149030-0-01	N-12	
146699-0-00	N-38		148569-0-01	L- 3		148663-0-01	G-33-19		149031-0-01	N-22	
147060-0-01	Z-12- 8		148570-0-01	Z-30		148664-0-01	G-33-20		149033-0-01	N-26	
147856-0-02	Z-15- 5		148571-0-01	L- 3		148665-0-01	G-33-18		149034-0-01	N- 3	
147858-0-01	Z-15- 6		148572-0-01	J-12		148666-0-01	G-33-24		149035-0-01	N- 1	
147908-0-01	Z-15		148573-0-01	J-14		148667-0-01	G-33-23		149036-0-01	N-28	
148005-0-01	E-24		148574-0-01	J-15 · N-30		148668-0-01	G-33-22		149037-0-01	N-59	
148011-1-01	A-15			L-16		148669-0-01	G-33-14		149040-0-01	N-62	
148394-0-00	B-33		148575-0-01	L-13		148670-0-01	G-33-17		149042-0-01	N-57	
148480-0-01	H-26		148577-0-01	J-18		148671-0-01	G-33-16		149043-0-01	N-36	
148481-0-01	E-39		148579-0-01	L- 1		148672-0-01	A-15- 9		149049-0-01	N-34	
	H-24		148580-0-01	J-16			G-33-13		149050-0-01	N-32	
148482-0-01	L-28		148581-0-01	J-20		148674-0-01	G-32		149052-0-01	N-52	



Parts No.	Ref. No.	Remark	Parts No.	Ref. No.	Remark	Parts No.	Ref. No.	Remark	Parts No.	Ref. No.	Remark
149055-0-01	N-42		151145-0-01	E-37- 2- 1		213792-0-01	T- 6-16		218873-0-00	T- 6-40	
149056-0-01	N-41			H-22- 2- 1		213794-0-01	S- 1-12		218874-0-01	T- 6-21	
	N-56- 5		151191-0-01	C-31		213802-0-01	T- 6-35		218875-0-01	T- 6-22	
149058-0-01	N-56		151507-0-01	D-13		213913-0-01	T- 6-98-10		218876-0-01	T- 6-72	
149061-0-01	N-29		151508-0-01	D-13		214002-0-01	T- 6-98-19		218877-0-01	T- 6-51	
149062-0-01	H- 9		151601-0-02	C-28- 4		214163-0-01	T- 7		218878-0-00	T- 6-51- 7	
149063-0-01	N-27		151602-0-01	D-31		214344-0-01	S- 2		218879-0-00	T- 6-51- 8	
149153-0-01	Q- 1		151602-0-02	A-33		214897-0-01	T- 6-43		218881-0-01	T- 6-74	
149155-0-01	Q- 1-17			L-53		215080-0-01	M- 1-10		218882-0-00	T- 6-52	
149156-0-01	Q- 1-17- 1		151604-0-01	C-12			M- 1-16		218884-0-00	T- 6-85	
149157-0-01	Q- 1-17- 6			E- 5					218885-0-01	T- 6-82	
149169-0-01	J- 1		151605-0-01	B- 2					218891-0-01	T- 6-83	
149174-0-01	L-39			D- 4			S- 1- 2		218892-0-01	T- 6-84	
149175-0-01	Z-30			D-39- 2			T- 6-44- 6		218893-0-01	T- 6-67	
149177-0-01	C-34		151609-0-01	C-28			T- 6-58		218894-0-01	T- 6-66	
	K-11		151884-0-00	K-27			T- 6-98-11		218895-0-01	T- 6-64	
149179-0-01	G-11		151885-0-00	K-34		215083-0-01	M- 1- 2		218896-0-00	T- 6-62	
149241-0-01	N-39		153112-0-01	A- 3					218902-0-01	T- 6-59	
149243-0-01	L-70		153168-0-01	D-12		215387-0-01	S- 1-25		218903-0-01	T- 6-88	
149244-0-01	L-69		153243-0-01	H-23		215491-0-01	T- 8		218905-0-01	T- 6-27	
149245-0-01	L-68		153244-0-01	H-23		216219-0-00	T- 6-85		218906-0-01	T- 6-44	
149246-0-01	K-33		153483-0-01	E-30		216225-0-01	T- 6-98- 1		218907-0-01	T- 6-44- 4	
149281-0-01	N-53		180157-0-01	B-25		216230-0-01	T- 6-98- 2		218910-0-00	T- 6-44- 5	
149282-0-01	J-58		180164-0-01	E-12		216232-0-01	T- 6-98-17		218911-0-01	T- 6-44-10	
149283-0-00	N-50		180321-0-01	D-34		216233-0-01	T- 6-98- 4		218912-0-00	T- 6-44-16	
149284-0-01	N-51		180949-0-01	E-15		216235-0-00	T- 6-98- 6		218913-0-01	T- 6-44- 1	
149285-0-01	N-21		180950-0-01	C- 4		216236-0-01	T- 6-98-24		218914-0-00	T- 6-44-13	
149286-0-01	N-45		181486-0-01	E- 6		216241-0-01	T- 6-98- 8		218915-0-01	T- 6-69	
149287-0-00	N-47		181712-0-01	J-25		216247-0-01	T- 6-92		218916-0-01	T- 6-44-18	
149288-0-01	G- 5		181713-0-01	J-27		216248-0-01	T- 6-91		218918-0-01	T- 6-44-21	
149290-0-01	Q- 1-20		181755-0-01	G-33		216277-0-01	T- 6-87		218919-0-01	T- 6-44-22	
149554-0-01	J-50		181756-0-01	G-33		216284-0-00	T- 6-44-14		218920-0-00	T- 6-44-23	
149569-0-01	H-11		200084-0-02	T- 6- 5		216286-0-01	T- 6-44- 9		218921-0-01	T- 6-44-19	
149570-0-01	Z-27		206156-0-01	T- 6-36		216299-0-01	T- 6-44- 7			T- 6-98- 2	
149768-0-01	G-34		206337-0-02	T- 6-93		216300-0-01	T- 6-44- 8		218922-0-01	T- 6-44-17	
149991-0-01	N- 5		210236-0-01	T- 7		216342-0-01	S- 1- 3		218923-0-01	T- 6-98	
150106-0-01	Z-12- 6		210237-0-01	T- 7		216345-0-00	S- 1-14		218924-0-01	T- 6-98- 3	
150139-0-01	Z-12- 9		210238-0-01	T- 7		216346-0-01	S- 3		218925-0-01	T- 6-98-20	
150151-0-01	Z-12		210240-0-01	T- 6-77		216351-0-01	S- 1-15		218926-0-01	T- 6-98-16	
150172-0-01	Z-12- 5		210421-0-00	T- 6-51- 6		216364-0-01	S- 1-22		218927-0-01	T- 6-98-21	
150175-0-01	Z-12-17		210938-0-01	T- 6-32		216373-0-01	S- 1- 1		218928-0-01	T- 6-96	
150179-0-01	Z-12- 7		210940-0-00	T- 6-31		216380-0-01	T- 6-79		218929-0-01	T- 6-95	
150180-0-00	Z-12-10		210941-0-02	T- 6-41		216837-0-01	T- 6-90		218930-0-01	T- 6-71	
150181-0-01	Z-12-19- 2			T- 6-51- 2		216870-0-01	S- 1- 7				
150182-0-00	Z-12- 9		210942-0-02	T- 6-42		216880-0-01	M- 1-13		218945-0-01	T- 6-98- 5	
150188-0-01	Z-12-13			T- 6-51- 1					218946-0-01	T- 6-98- 7	
150189-0-01	Z-12-19- 1		210948-0-01	T- 6-51- 5		216905-0-01	S- 1-23		218947-0-01	T- 6-98-23	
150193-0-01	Z-12		210965-0-01	T- 6-24		217093-0-01	M- 1- 7		218951-0-01	T- 6-14	
150202-0-01	Z-12- 6- 2		210973-0-01	T- 1					218952-0-01	T- 6-81	
150553-0-03	A-13		211003-0-01	T- 7		217169-0-00	T- 6-50		219208-0-01	S- 1	
150557-0-01	Z-23		211528-0-01	T- 6- 3		217280-0-01	T- 6-44-20		219210-0-00	S- 1- 4	
150917-0-01	C-33			T- 6-44-15			T- 6-65				
151007-1-01	F-48			T- 6-78		218821-0-01	S- 1-21		219211-0-00	S- 1-20	
151016-0-01	H-22			T-10		218823-0-01	S- 1- 5		219212-0-00	S- 1-19	
151028-0-01	E-37- 1- 4		211546-0-01	T- 7		218830-0-01	T- 6		219214-0-01	S- 1-26	
	H-22- 1- 1		212041-0-01	T- 7		218831-0-01	T- 6-20		219225-0-00	S- 1-24	
151029-0-01	E-37- 2- 2		212042-0-01	T- 7		218851-0-01	T- 6-34		219405-0-01	T- 6-75	
	H-22- 2- 2		212251-0-01	R- 1-11		218860-0-01	T- 6-63		219474-0-00	T- 6-54	
151030-0-01	E-37- 2- 3		212425-0-01	T- 7		218861-0-01	T- 6-15		219475-0-00	T- 6-85	
	H-22- 2- 3		212426-0-01	T- 7		218861-0-02	T- 6-17		219480-0-01	T- 6	
151080-0-01	D-18		212544-0-01	T- 6-98-25		218861-0-03	T- 6-18		219704-0-01	S- 1	
151081-0-01	D-52		213073-0-01	T- 7		218862-0-01	T- 6- 8		219705-0-00	S- 1- 4	
151082-0-01	E- 1		213646-0-01	T- 5		218863-0-01	T- 6- 1		219707-0-01	S- 1	
151083-0-01	F-37		213650-0-01	T- 2		218864-0-01	T- 6-49		219708-0-00	S- 1- 4	
151084-0-00	F-27		213748-0-01	T- 6- 7		218865-0-01	T- 6- 4		219946-0-01	S- 1	
151101-0-01	A- 1		213750-0-00	T- 6-51- 3		218866-0-01	T- 6-47		220067-0-01	M- 1	
151138-0-01	E-37- 2		213752-0-01	T- 6-25		218867-0-01	T- 6-48		220093-0-01	S- 1	
151139-0-01	E-37- 2		213757-0-02	T- 6-80		218870-0-01	T- 6-44- 2		220095-0-01	S- 1	
			213760-0-01	T- 6-94		218871-0-01	T- 6-37		290439-0-00	T- 6-53	
151146-0-01	F-37- 2- 1		213765-0-01	T- 6-23		218872-0-01	T- 6-39		403616-0-01	K-24	



